

**REQUEST FOR QUALIFICATION FOR  
UTILITY-SCALE SOLAR PHOTOVOLTAIC  
PROJECT IN ARMENIA**

MAY 2020

## Notice

All information contained in this RFQ, including financial, geographic, commercial, legal and technical information, has been included in this RFQ for illustrative and information purposes only. Each Applicant shall be solely and fully responsible for satisfying itself as to the information required to submit an application to qualify, and to undertake each Project in accordance with the terms of its application if the application is successful and the Applicant subsequently submits a Bid to undertake the Project.

Whilst the information contained in this RFQ has been prepared in good faith, it does not purport to be comprehensive nor to have been independently verified. Neither The Tendering Authority nor its employees, agents or Advisors make any representation or warranty, express or implied, with respect to the veracity, adequacy, accuracy, reasonableness or completeness of the information contained in this RFQ or with respect to the information on which it is based or in respect to any written or oral information or representation given or made or to be given or made by The Tendering Authority or any of its Advisors to any Applicant or its professional Advisors, whether given or made prior to or after the issue of this RFQ (collectively, the "**Information**").

The Tendering Authority and its Advisors hereby expressly disclaim any and all liability (other than in respect of fraudulent misrepresentation) arising out of or in relation to the Information (including in relation to any omissions therefrom) and in respect of the use of and/or reliance on such Information by Applicants and/or their Advisors.

## Acronyms and abbreviations

AMD	Armenian Dram
COD	Commercial Operation Date
DFBOO	Design, Finance, Build, Own and Operate
ENA	Electric Networks of Armenia
EN	European Standards
EPC	Engineering, Procurement and Construction
EPSO	Electric Power System Operator
ESIA	Environmental and Social Impact Assessment
Home Country	The country where a Prospective Bidder has its principal place of business (measured by reference to the largest proportion of its turnover) and, in addition, where the Prospective Bidder has a Parent Company, the country (if different) where that Parent Company has its principal place of business (measured on the same basis)
IEC	International Electro-technical Commission
ISO	International Standards Organization
IPP	Independent Power Producer
MW	Megawatt
MWp	Megawatt peak
O&M	Operation and Maintenance
Parent Company	A company that is a Holding Company for a Prospective Bidder
OEM	Original Equipment Manufacturer
PSRC	Public Services Regulatory Commission
PV	Photovoltaic
RFP	Request for Proposal
RFQ	Request for Qualification
S&P	Standard & Poor's
UN	United Nations
US\$	United States Dollar
PPA	Power Purchase Agreement

PFA	Project Founders' Agreement
TPP	Thermal Power Plant

## 1. Request for Prequalification

- 1.1. Taking into account the decree 1922 – L adopted by the Government of the Republic of Armenia on December 26, 2019, according to which the Government of Armenia approved “Masdar Armenia” Investment Project, the Ministry of Territorial Administration and Infrastructure of the Republic of Armenia has initiated to undertake an international tender that will invite other companies to submit a competitive tariff.
- 1.2. Armenia Renewable Resources and Energy Efficiency Fund (the Fund) by the request of the Ministry of Territorial Administration and Infrastructures of the Republic of Armenia is seeking private developers or consortia for a project to design, finance, build, own, and operate the grid-connected 200 MW solar PV power plant (the Project – Ayg-1). The Project will have a requirement for an AC capacity of 200 MW at the Electrical Delivery Point and will be located between the communities of Talin, Dashtadem and Ashnak in the Aragatsotn marz of the Republic of Armenia.
- 1.3. The Project will be developed on a Design, Finance, Build, Own, and Operate (DFBOO) basis under one special purpose company (the Project Company) to be jointly owned by the Successful Bidder (85% ownership) and Armenian National Interest Fund CJSC (ANIF) (15% ownership). The Project Company is to be established and incorporated in the Republic of Armenia specifically for the needs of this Project.<sup>1</sup>
- 1.4. In the interests of convenience, and unless otherwise specified, references in this Request for Prequalification (RFQ) to:
  - (a) the Project shall be construed as referring to the Project described in Section 1.2,
  - (b) the Developer shall be construed as referring to the development company or consortium described in Section 1.2 to whom the Project is awarded; and
  - (c) the Seller shall be construed as referring to the Project Company described in Section 1.3 through which the relevant Developer will implement the relevant Project.

---

<sup>1</sup> Note to a Prospective Bidder: ANIF is a state-owned company, whose 15% ownership in the Project Company will be one of the conditions for the Successful Bidder. ANIF will be granted 15% shareholding in the Project Company as a compensation for local partnership. The details shall be elaborated upon in the Appendix 7 to this RFQ and the Shareholders Agreement, which will be published together with the RFP.

- 1.5. The selection of a bidder to develop the Project will be conducted in two stages. The first stage is the RFQ to prequalify the prospective bidders with required experience and financial resources to deliver the Project as per the requested timeline. The second stage will require bidders to submit proposals in response to the Request for Proposals (RFP). The initiator of the investment project, Masdar Abu Dhabi Future Energy Company PJSC – Masdar, will be given an opportunity to match its offer with the lowest bid tariff proposed by other Pre-Qualified bidder by proposing at least USD 0,1 cent per kilowatt hour (kWh) lower tariff in case it has not quoted the lowest tariff. The timetable, which is contained in Section 6, provides an overview of the main components of the tender process for the Project.
- 1.6. The bidders should note that the high-level description of the Project set out in this RFQ represents the Fund’s present approach and may undergo non-material modification at a later date. A more detailed description of the Project and other details regarding the commercial agreements under the Project will be included in the RFP.
- 1.7. The Fund now invites prospective bidders (each, a Prospective Bidder) capable of meeting the qualification criteria set out in this RFQ document to submit prequalification applications electronically in accordance with the requirements of this RFQ document (each, a Prequalification Application). However, to be eligible to participate, Prospective Bidders will be required to register for the prequalification and make a payment in the amount of **US\$1,000** through a wire transfer to the commercial bank account of the Fund presented in the Appendix 3 to this RFQ. The evidence confirming the payment should be included in the Prequalification Application.
- 1.8. Only bidders designated as prequalified bidders pursuant hereto (Prequalified Bidders) will be eligible to participate in the RFP stage of the selection process to be initiated by the Fund in due course.
- 1.9. Prequalification Applications must be electronically submitted in accordance with the requirements of this RFQ by **17:00 Armenia Time, July 1st, 2020**. Prequalification Applications must be packaged, labelled, and submitted in accordance with the requirements of this RFQ by **15:30 Armenia Time, July 24th, 2020**.
- 1.10. In case less than three Prequalification Applications are received as indicated in clause 1.9 of this RFQ, the second, RFP, stage of the tender will not be held.

## 2. Disclaimer

- 2.1. The information contained in this RFQ was prepared by the Fund, and is furnished solely for the purpose of assisting Applicants in making their own evaluations of the Project. It does not constitute an offer in relation to the Project.

- 2.2. The information contained in, or otherwise made available to Prospective Bidders pursuant to, this RFQ does not purport to be all-inclusive or to contain all the information that an Applicant or its advisers may require or desire in relation to the Project. The Applicant should form its own views as to what information is relevant and make its own investigations, projections and conclusions and consult its own advisers to verify independently such information, and to obtain any additional information that it may require, prior to submitting the Prequalification Application.
- 2.3. Neither the Fund nor the Government of Armenia nor their respective employees, officers, agents and advisers shall have any responsibility for the accuracy or completeness of the contents of this RFQ or any information made available to Prospective Bidders pursuant to this RFQ (including any opinions expressed or implied) and no representation or warranty, explicit or implied, is given by any such person as to the accuracy or completeness of such information or opinions. In particular, no representation or warranty is given as to the accuracy, reasonableness or likelihood of achievement of any future projections, prospects or returns.
- 2.4. The Fund reserves the right, with the permission of the Minister of Territorial Administration and Infrastructure of the Republic of Armenia, in its absolute discretion, at any stage and without notice to change the structure and timing of the tender process, to amend the information contained in or otherwise made available to Prospective Bidders pursuant to the RFQ, or to terminate the tender process itself. The Fund will ensure that relevant information is publicly available as well as notify the participants/Prospective Bidders about relevant changes through its official website within one (1) working day. In case of significant changes pursuant to this clause, the Fund will ensure that appropriate time to adjust is provided.
- 2.5. Neither the Fund nor the Government of Armenia nor their respective employees, officers, agents and advisers shall have any responsibility or liability for any costs, expenses or other liabilities incurred by any Prospective Bidder.

### **3. Technical Description**

#### **3.1. Scope of Technical Responsibility**

- 3.1.1. The Project includes the development, financing, design, engineering, construction, ownership, operation and maintenance of a solar PV power plant with an AC capacity of 200 MW solar PV power plant, at the Electrical Delivery Point. The Ayg-1 Solar IPP is expected to be commissioned and the contracted capacity made available by Q4, 2023<sup>2</sup>.

---

<sup>2</sup> To be reconfirmed in RFP.

- 3.1.2. The Project is expected to be located 4km South East of the town of Talin, in the Aragatsotn Province of Armenia with a foot print of approximately 520Ha.
- 3.1.3. Bidders will be encouraged to develop the Project on a sound technical basis using proven technology with high efficiency, flexibility of operation and an environmentally compliant configuration, as well as safe and reliable processes and operating procedures. Furthermore, the capacity and plant layout at the site will need to be optimized to fit within the constraints of the available site.
- 3.1.4. The EPC contractor proposed by the Bidders must be of high quality with demonstrable expertise to design, procure, construct and commission the Project, with a proven track record of completing projects on-time and with a high emphasis on health, safety and environmental compliance.
- 3.1.5. Additional information on the Site, potential access to Site, plot plan of Site, interconnection points and areas available for plant installation and site construction facilities will be provided as part of the RFP to the extent that this information is available.<sup>3</sup> However, Bidders will be responsible for conducting their own independent investigations for acquiring all relevant information required to propose an appropriate design for the Project which must be compliant with the RFP.
- 3.1.6. The Project is required to be developed, constructed and operated according to national environmental protection regulations and stipulations. The development of comprehensive ESIA by the Successful Bidder will be required as part of the Project. The Successful Bidder will be responsible for obtaining all necessary environmental licenses, permits, agreements for the respective Project.
- 3.1.7. The technical specification to be included in the RFP will be purely functional as it will include:
- minimum functional specifications;
  - applicable standards;
  - scope of plant;
  - commissioning and testing requirements;
  - dispatching and operational requirements;
  - technical interfaces;
  - health and safety requirements;
  - environmental aspects;
  - architectural requirements; and
  - waste disposal and secondary use after the expiration date.

---

<sup>3</sup> To be reconfirmed in RFP.

- 3.1.8. The RFP will request Bidders to provide technical and performance data, engineering drawings etc., which will be evaluated to ensure compliance with the technical requirements of the Project.
- 3.1.9. With respect to the Project, the Successful Bidder will be responsible for obtaining all necessary permits and approvals for construction and operation. ANIF will fully support the Successful Bidder on obtaining the necessary permits and approvals.

### **3.2. Project Development and Financing Overview**

- 3.2.1. The Project will be developed on a DFBOO basis under one special purpose company (the Project Company) to be jointly owned by the Successful Bidder (85% ownership) and Armenian National Interest Fund CJSC (ANIF) (15% ownership). There will be no investment from any Government entity in the Project Company. In addition to funding from the Project Company's shareholders, the Fund expects the Project to be financed either through balance sheet or non-recourse commercial debt financing.
- 3.2.2. The Project Commercial Operations Date is expected to be achieved in Q4 2023. Following the first decision of the PSRC on setting the electricity tariff, the Project Company will supply the entire net power output to the private power distribution company – Electric Networks of Armenia (ENA) CJSC – under a 20-year Power Purchase Agreement (PPA). The Project Agreements will also include a Government Support Agreement (GSA) and other agreements with the scope and provisions to be defined in due course. The final forms, as practicable, of the Project Agreements will be shared with the Prequalified Bidders as part of the RFP.

### **3.3. Land Rights Agreement**

- 3.3.1. Ownership rights for up to 520ha land required for the Project will be provided free of charge to ANIF pursuant to the land allocation agreements concluded between the latter and the relevant state body / community. Before the land is given to ANIF, the purpose of the land will be changed and area measurement in WGS-84 (ArmREFo2) National Geodetic Coordination System will be performed. ANIF will grant the right to use the land to the Project Company free of charge.

### **3.4. Project Company Founding Agreement**

- 3.4.1. The successful Bidder will be required to enter into a Project Company Founding Agreement (FA) with ANIF under the terms specified in Appendix 7.

## **4. Prospective Bidder Composition, Participation Restriction, and Costs**



- 4.1. Considering the capacity of the Project, it is imperative that the Prospective Bidder must demonstrate successful international experience gained from developing power generation plant(s) outside of their Home Country.
- 4.2. A Prospective Bidder may be a company, firm, corporate body or other legal entity or a consortium (Consortium) comprised of two or more such entities (each a Consortium Member), subject always to the requirements set forth in this document. The Prospective Bidder, or if the Prospective Bidder is a Consortium, each Consortium member, must be a business organisation duly organised and existing and registered in good standing under the laws of its country of incorporation.
- 4.3. The Prospective Bidders should note that there is no requirement for a Consortium to include any Original Equipment Manufacturers (OEM) as Consortium Members. Each Prequalified Bidder will be permitted (as part of its Proposal) to list several OEMs as potential suppliers of the major components that will ultimately make up the Project if such Prequalified Bidder is successful.
- 4.4. An entity that is a potential O&M contractor or EPC contractor may be involved in its contractual capacity alone with more than one Prospective Bidder and in this capacity will not be treated as being part of the Prospective Bidder. However, where an O&M contractor and/or EPC contractor is also participating directly as a Prospective Bidder then it may only participate in an O&M or EPC contracting capacity in more than one Prospective Bidder after obtaining written approval from the Fund prior to the submission of the Prequalification Form.
- 4.5. The intention is to enable Prospective Bidders to maintain competition amongst several OEMs, while also allowing OEMs to retain flexibility to offer their products to multiple Prequalified Bidders. Any Prospective Bidder intending to form a Consortium that does include an OEM is advised to comply with the technical specifications set out in Appendix 2.
- 4.6. Each Consortium shall appoint and authorize a consortium leader (Consortium Leader), having regard to the following requirements that will ultimately be applied to the Project through the Project Agreements:
  - A. At the date of signature of the Project Agreements and for two years after the Commercial Operations Date:
    - i. The Consortium Leader shall (between them) hold a controlling interest in the Project Company and for these purposes a controlling interest shall comprise:
      - a. A direct or indirect shareholding of more than 50% of the share capital of the Project Company;

- b. The power to elect a majority of the board of directors (or other similar constituent body) or otherwise direct the management and policies of the Seller, directly or indirectly; and
  - c. The absence of any contractual or other arrangement that purports to transfer, assign or delegate to a third party the beneficial interests described in paragraphs (a) and (b) above.
- B. The Consortium Leader shall be authorized to represent and irrevocably bind all Consortium Members in all matters connected with this process for prequalification and selection of bidders and award of the Project (the Process), including but not limited to the submission of the Prequalification Application on behalf of the Consortium.
- 4.7. No legal entity or other person may participate or be involved directly or indirectly (including via an affiliate) in more than one Prequalification Application in any capacity whatsoever, provided that this requirement shall not itself prevent any OEM or contractor from offering equipment or services respectively to multiple Prequalified Bidders.
- 4.8. The identity of Prospective Bidders (including the composition of any Consortium) shall be fixed with effect from the deadline for submitting Prequalification Applications. No change in such identity (or such composition), including any partnering arrangements, shall be permitted without the written approval of the Fund in its exclusive discretion until after signature of, and then only as expressly provided in, the Project Agreements.
- 4.9. Each Prospective Bidder shall bear all costs associated with the preparation and submission of its Prequalification Application, including without limitation all costs and expenses related to the Prospective Bidder's preparation of responses to any questions or requests for clarification that the Fund may submit.

## **5. Prequalification Application**

### **5.1. Introduction**

- 5.1.1. Each Prequalification Application and all correspondence and documents related thereto shall be submitted in the language specified in Appendix 3. Any material not submitted in such language shall be disregarded for all purposes.
- 5.1.2. Each Prequalification Application shall comprise the following documents:
  - a. Part I – evidence that the relevant Prospective Bidder satisfies at least one of the Technical Criteria (see Section 5.2);

- b. Part II – evidence that the relevant Prospective Bidder satisfies the relevant Financial Criterion (see Section 5.3);
  - c. Part III – evidence that the relevant Prospective Bidder satisfies all of the Legal Criteria (see Section 5.4); and
  - d. Part IV – prequalification form and other documents or information (see Section 5.5).
- 5.1.3. No Prequalification Application shall contain prices or price schedules or any other reference to rates and prices for undertaking the Project. Any Prequalification Applications containing any such price information will be rejected and the relevant Prospective Bidder disqualified.
- 5.1.4. Subject to Section 5.1.3, a Prospective Bidder shall be free to include additional materials (including company brochures and other pre-printed literature) in its Prequalification Application, provided that these are bound separately from Parts I to IV as described above. However, the Fund shall have no obligation to review such materials or to consider them in its evaluation of the relevant Prospective Bidder's Prequalification Application. It is therefore for each Prospective Bidder to ensure that all information relating to its qualification is contained in Parts I to IV.

## **5.2. Technical Qualification**

- 5.2.1. Prospective Bidders shall be required to demonstrate experience of developing, constructing and operating the below Technical Criterion and to submit proof thereof as set out in Section 5.2.3.
- 5.2.2. The below requirements will need to be satisfied for a power plant to be recognized as compliant with the above Technical Criterion:
- A. The Prospective Bidder or in the case of a Consortium, the relevant experience must be demonstrated by the Consortium Leader:
    - i. one or more grid-connected solar photovoltaic power plants operating anywhere in the world with a minimum aggregate capacity of 200MW AC; or
    - ii. one or more operating grid-connected power plant(s) of any other renewable technology anywhere in the world with a minimum aggregate capacity of 400 MW AC;

- B. In all cases, the relevant experience must be at the corporate level rather than merely at the level of one or more individuals employed or otherwise engaged by the Consortium Leader;
  - C. The Prospective Bidder or the Consortium Leader must have held a 25% or greater share directly or indirectly in the relevant power plant(s) at financial close, during construction and for at least two years of commercial operation;
  - D. Within 10 days from the date of the written request from the Fund, evidence should be provided proving that the listed power plants have achieved average annual availability of 95%. The average annual availability will be calculated based on the period of time when the relevant power plant was capable of generating electricity if dispatched, but will exclude all periods of outage, regardless of whether scheduled or unscheduled. Average annual availability of power plants should be measured starting six months from commercial operation date (COD).
- 5.2.3. For each power plant submitted by the Prospective Bidder as evidence of meeting a Technical Criterion, the Prospective Bidder shall provide:
- A. A clear statement identifying to which Technical Criterion the experience relates, together with the following information: (i) name, (ii) location, (iii) description, including generating capacity, (iv) commercial operations date, (v) role of the Prospective Bidder / Consortium Leader, (vi) average availability as stipulated in section 5.2.2(d) and (vii) direct or indirect shareholding in the relevant plant; and
  - B. Verifiable evidence<sup>4</sup> confirming the information required under paragraph (A) above.

### 5.3. Financial Qualification

- 5.3.1. A Prospective Bidder shall be required to satisfy one of the following two financial prequalification criteria (each a Financial Criterion) and to submit the documentation described in Section 5.3.3.
- A. If the Prospective Bidder comprises a single entity, such entity shall have had:
    - (i) A Net Worth of at least US\$100 million or equivalent; and
    - (ii) A Net Worth to Total Assets ratio of at least 20%.

---

<sup>4</sup> The evidence should be in English and provide the Fund reasonable opportunity to check the existence of such evidence.

B. If the Prospective Bidder is a Consortium, then:

- (i) The Consortium Leader shall: (a) have had a Net Worth of at least US\$100 million or equivalent, and (b) have had a Net Worth to Total Assets ratio of at least 20%; and

In each of the above cases, the compliance will need to be demonstrated as at the end of each of the most recent two full financial years for which audited financial statements are available as at the deadline for responding to this RFO; and

C. Any Prospective Bidder unable to satisfy the relevant Financial Criterion due to circumstances of any Consortium Member, shall nonetheless be deemed to have satisfied the relevant Financial Criterion in the following cases:

- (i) If Consortium Leader does not satisfy the relevant Net Worth to Total Assets ratio requirement, the Consortium Leader shall nonetheless be deemed to have satisfied such test if either:

- a. It had a Net Worth of at least US\$500 million and a Net Worth to Total Assets ratio of at least 10%; or

- b. Its Prequalification Application includes a letter from its Chief Financial Officer or equivalent in support of all financial obligations of Consortium Leader for the purposes of the project from a company that: (i) holds a direct or indirect shareholding of at least 75% in the relevant Consortium Member, (ii) has an investment grade credit rating in foreign currency by S&P/Moody's/Fitch; and (iii) itself complied with the financial criteria in (a) above as at the end of each of the most recent full financial years for which audited financial statements are available as at the Prequalification Application submission deadline.

- (ii) In cases where the specific financial circumstances of the relevant Consortium Leader are due to such Consortium Leader being owned by an investment fund and, as a result, being unable to satisfy one or more of the applicable Net Worth tests and Net Worth to Total Assets ratio tests, it shall nonetheless be deemed to have satisfied the relevant test(s) if the relevant Prequalification Application includes:

- a. Duly authorized copies of irrevocable commitments satisfactory to the Fund from one or more limited partners or other investors in the

relevant fund of at least US\$300 million as at the date falling two weeks prior to the Prequalification Application submission deadline;

b. A letter from the Chief Financial Officer, Chief Investment Officer or equivalent of the manager of such fund:

(1) confirming the availability as at such date of an aggregate amount of at least \$75m (or equivalent) in uncommitted funds

(2) committing to advise the Fund immediately upon such funds being irrevocably allocated to another purpose

(3) acknowledging that the Prospective Bidder will be subject to additional requirements in the Process as follows:

- if designated as a Prequalified Bidder, an additional requirement under the RFP to provide as part of any final proposal a guarantee or letter of credit from an entity which has an international long term credit rating in foreign currency by Standard & Poor's Ratings Services, Moody's Investors Service or Fitch Ratings Limited of at least A-, A3 or A- respectively in an amount of no less than US\$75m and
- if ultimately awarded the Project, an additional requirement under the Project Agreements for such fund manager to retain a controlling interest in the relevant Consortium Leader until the second anniversary of the Commercial Operations Date as defined in the PPA.

(4) confirming that an aggregate amount of at least US\$1.2 million per project MW has been provisionally set aside for the project; and

(5) committing to advise the Fund immediately upon such funds being irrevocably allocated to another purpose.

5.3.2. For the purposes of this Section 5:

a. **Net Worth** shall be calculated as follows: subscribed and paid-in equity *plus* reserves *minus* revaluation reserves *minus* miscellaneous expenditure not written off.

b. **Total Assets** shall be derived from the audited financial statements for the relevant financial years.

- 5.3.3. The Prospective Bidder shall provide for itself or, where the Prospective Bidder is a Consortium, for the Consortium Leader :
- a. Audited financial statements duly certified by a certified public accountant for the most recent three full financial years for which such statements are available, including in each case a consolidated balance sheet, income statement, statement of cash flows and accompanying notes; and
  - b. A step-by-step calculation of Net Worth and Total Assets (including, in the case that the audited financial statements provided pursuant to paragraph (a) do not clearly refer to the accounting concepts comprised in the above definition of Net Worth and Total Assets, appropriate additional documentation, explanation and/or cross-references to such audited financial statements as it may consider appropriate).

#### 5.4. Legal Qualification

- 5.4.1. For the purposes of this RFQ, the Relevant Person means, with respect to a person:
- a. any company financing, investing in, developing, operating or maintaining Independent Power Project projects that is controlling, controlled by or under common control with, such person;
  - b. any director, senior executive or manager either of such person or of any company referred to in paragraph (a);
  - c. Any consultant, agent or representative supporting such person in connection with the Process or the Project; and
  - d. Any person with an aggregate ultimate beneficial interest in at least 5% of the share capital or ownership interest in such person (howsoever held).
- 5.4.2. Without prejudice to Sections 5.2 and 5.3, to be declared a Prequalified Bidder, a Prospective Bidder or, where the Prospective Bidder is a Consortium, each Consortium Member shall be required to satisfy all of the following legal prequalification criteria (each a **Legal Criterion**, together the **Legal Criteria**) and to submit the documentation described in section 5.4.3:
- a. it and all Relevant Persons are not in bankruptcy or liquidation, or receivership, or wound up, or their affairs are not being administered by a court or a judicial officer, or their business activities have not been suspended or they are not the subject of legal proceedings of any of the foregoing and have a reasonable expectation of being able to discharge all financial liabilities as they fall due;

- b. neither it nor any Relevant Person has been convicted of fraud, corruption, collusion or money laundering or for a criminal act involving dishonesty, physical violence or intentional harm to human life, or for any criminal offence related to their professional conduct within a period of five years of commencement of the tender proceedings, nor is the subject of credible and/or persistent allegations related to, or is under investigation for, such criminal activities;
- c. it is not aware of any conflict of interest or potential conflict of interest arising from prior or existing contracts or relationships which affects or could affect its or (upon formation) the Seller's (as applicable) potential involvement in the Project (other than supply or service agreements among members of the Consortium Member's corporate group in the ordinary course);
- d. neither it nor any Relevant Person has any tax liabilities, outstanding social security contributions or liabilities in respect of judgments awarded by any court or similar proceedings in the period of three years prior to the date of this invitation, save in each case to the extent that it has made suitable accounting provision for such liabilities in accordance with applicable accounting regulations;
- e. neither it nor any Relevant Person has previously been excluded from tender or other public procurement processes in the Republic of Armenia;
- f. neither it nor any Relevant Person has had a concession or PPA terminated that is attributable to an event of default of the concessionaire in the event of a concession or a seller of power in the event of a PPA;
- g. Neither it nor any Relevant Person:
  - (i) is included as a debarred person pursuant on the public sanctions list of any multilateral development bank that is party to the Agreement on Mutual Enforcement of Debarment Decisions of 9 April 2010 ([www.crossdebarment.org](http://www.crossdebarment.org)); or
  - (ii) is included on any sanctions lists promulgated by the UN Security Council or its Committees, or any other recognized international sanctions list; and
- h. neither it nor any Relevant Person has operations (directly or through any subsidiary) or carries out transactions that are not in compliance with the sanctions promulgated by the UN Security Council or its Committees or national sanctions in the Republic of Armenia.



- i. Neither it nor any Relevant Person was debarred or suspended from participation in the public procurement tenders at their respective countries.
- 5.4.3. The Prospective Bidder, or if the Prospective Bidder is a Consortium, each Consortium Member shall in addition provide the following:
- a. a confirmation letter in the form attached as Appendix 4;
  - b. a comprehensive organization chart showing – or narrative text describing – how it is owned, up to the level of ultimate beneficial ownership by individuals and identifying by name all legal or natural persons holding (at any level in the organization structure) an aggregate ultimate beneficial interest of at least 5%;
  - c. certified copies of up-to-date constitutional documents (e.g. certificate of incorporation and/or registration, extract from commercial registry, bylaws etc.); and
  - d. A power of attorney substantially in the form attached as Appendix 5 authorizing the person(s) signing and submitting the Prequalification Application on behalf of the relevant Prospective Bidder or each Consortium Member (as applicable) so to do.
  - e. A formal confirmation letter that the Prospective Bidder or any of the Consortium Members (if the Prospective Bidder is a Consortium) are not debarred or suspended from participation in public procurement tenders at their respective countries.

## **5.5. Prequalification Form and Application Fee**

- 5.5.1. Each Prospective Bidder shall provide a prequalification form in the form attached as Appendix 6 (Prequalification Form).
- 5.5.2. Each Prospective Bidder shall provide evidence of payment to the Fund of the application fee (RFQ Participation Fee) stipulated in Appendix 3 at the bank account specified in such Appendix, together with the following data: (a) name of the Prospective Bidder, (b) date of payment of the RFQ Participation Fee and (c) name, email address and telephone numbers of contact person for enquiries about payment of the RFQ Participation Fee.

## **6. Process and Timeline**

### **6.1. Clarifications**

Any Prospective Bidder requiring any clarification of any part of this RFQ or of any of the requirements set out herein may notify the Fund in writing at the email address indicated in Appendix 3 at any time prior to the deadline for such requests specified in the Estimated Timetable (as defined below). To the extent that the Fund responds to any or all such requests (and it shall not be obliged to do so), it shall send such response(s) to all Prospective Bidders in one or more batches and without identifying the source of the original request(s).

## 6.2. Estimated Timetable

6.2.1. The Estimated Timetable is presented below.

Activity	Target Deadline
RFQ issued	Zero (Reference) Date (T <sub>0</sub> ) (May 22nd, 2020)
Clarification request deadline	T <sub>7</sub> to T <sub>14</sub> (till June 5th, 2020)
Bids submission (electronically)	T <sub>40</sub> (17.00 Armenian time, on July 1st, 2020)
Bids submission (original documents)	T <sub>63</sub> (15.30 Armenian time, on July 24th, 2020)
Announcement of Qualified Bidders	T <sub>70</sub> (July 31st, 2020)
Issuance of RFP	T <sub>73</sub> (August 3rd, 2020)
RFP pre-bid meeting	T <sub>77</sub> to T <sub>89</sub> (till August 19th, 2020)
Site Visit with Local Experts	T <sub>90</sub> (August 20th, 2020)
Bids submission	T <sub>123</sub> (September 22nd, 2020)
Announcement of the Winning Bidder	Zero (Reference) Date (Z <sub>0</sub> ) (October 15th, 2020)
Execution of Government Support Agreement	Z <sub>0</sub> + 30 days
Execution of PPA	Z <sub>0</sub> + 95 days

6.2.2. The Estimated Timetable is presented for indicative purposes only and the Fund shall not incur any liability whatsoever in respect thereof. The Fund, upon the approval by the Ministry of Territorial Administration and Infrastructure of RA, may

amend the Estimated Timetable (and any other information in Section 6.2.1) at any time in its sole discretion, provided that in no circumstance shall any such amendment result in an acceleration of the Prequalification Application submission deadline. The Fund shall give notice to Prospective Bidders as soon as reasonably practicable after making any such changes (whereupon all references to time and deadlines in this RFQ shall be deemed amended accordingly).

### 6.3. Format, Signing and Submission of Prequalification Applications

- 6.3.1. The Prequalification Application shall be submitted in PDF format (split into separate files for each of Parts I to IV as described in Section 5.1.2) electronically to [zaruhi.gharagyozyan@r2e2.am](mailto:zaruhi.gharagyozyan@r2e2.am), [r2e2fund@gmail.com](mailto:r2e2fund@gmail.com) emails by July 1st, 2020, 17:00, under the following subject: **200MW AC AYG-1 SOLAR PV PROJECT – REQUEST FOR PREQUALIFICATION. After electronic submission of the Prequalification Application**, each Prospective Bidder shall also prepare and submit one original and the relevant number of copies of its Prequalification Application as specified in Appendix 3 together with a USB flash-drive (in either case password-protected to prevent amendment) containing a complete scanned PDF copy of the original Prequalification Application (split into separate files for each of Parts I to IV).
- 6.3.2. The person(s) duly authorized by the power(s) of attorney referred to in Section 5.4.3(d) to bind the Prospective Bidder shall sign the Prequalification Application by:
  - a. Signing the original of the relevant Prequalification Application; and
  - b. Initialing all of the pages of the original of the Prequalification Application.
- 6.3.3. The Prequalification Application shall be typed and shall contain no alterations, omissions or additions. Any manuscript text, other than the signature and initials referred to in Section 6.3.2, will be ignored.
- 6.3.4. The original copy of must be submitted to the Fund: Sayat-Nova 29/1, Yerevan, Armenia by July 24th, 2020. The Prospective Bidder shall seal the original Prequalification Application in envelopes, complying with the requirements of Section 5, and shall mark the envelopes as **Prequalification Application – Original, Prequalification Application**. Such envelope shall specify the name and address of the Prospective Bidder (or in the case of a Consortium, the names of all Consortium Members and the address of the Consortium Leader, to enable the relevant Prequalification Application to be returned unopened in the event that it is submitted beyond the deadline for submission). The envelopes shall be sealed in a larger outer envelope, which shall be labelled as follows (with no additional text, information or markings): **200MW AC AYG-1 SOLAR PV PROJECT – REQUEST FOR PREQUALIFICATION**.

6.3.5. Late applications will not be accepted.

6.3.6. The outer envelope shall not disclose the Prospective Bidder's or any Consortium Member's identity or address.

#### **6.4. Evaluation of Prequalification Applications**

6.4.1. The Fund shall first examine each Prequalification Application to determine whether it is complete in form and substance.

6.4.2. Where the Fund deems it convenient or necessary for clarification purposes, it may – but shall not be so obliged – request supplementary information or documentation from a Prospective Bidder (whether relating to such Prospective Bidder, any Consortium Member, the relevant Prequalification Application or any document submitted as part thereof or otherwise in connection therewith) for determining its eligibility for prequalification. Whenever such request is made, the Prospective Bidder shall provide the required information or documentation to the Fund within seven days (or such longer period as is specified in the request from the Fund).

6.4.3. Once the Fund has concluded the clarification process (if any), it shall proceed to formal evaluation of the Prequalification Applications. Such evaluation shall be on a simple "pass/fail" basis as follows:

a. Any Prospective Bidder whose Prequalification Application demonstrates compliance with the requirements of Section 5 shall be designated as a Prequalified Bidder. The Fund shall notify all Prequalified Bidders simultaneously whether their Prequalification Applications have been accepted and shall proceed when ready to open the data room to all such Prequalified Bidders.

b. Any Prospective Bidder whose Prequalification Application fails to demonstrate compliance with the requirements of Section 5 shall be designated as a non-prequalified bidder. The Fund shall notify all such non-prequalified bidders simultaneously that their Prequalification Applications have been rejected.

6.4.4. For the purposes of the formal evaluation referred to in Section 6.4.3, the Fund shall be entitled (but shall not be so obliged) to disregard minor deviations from the formal requirements of Section 5, provided that it is clear from the relevant Prospective Bidder's Prequalification Application (and from any subsequent clarifications pursuant to Section 6.1) that the Prospective Bidder satisfies at least one of the Technical Criteria, the relevant Financial Criterion and all of the Legal Criteria.

6.4.5. The Fund shall be entitled to disqualify any Prospective Bidder from the Process, whether during the formal evaluation referred to in Section 6.4.3 or subsequently, if it discovers that any statement in any document provided by such Prospective Bidder as part of or in connection with its Prequalification Application is or was when made incorrect or misleading in any material respect.

## **6.5. Termination or Variation of Process**

6.5.1. Notwithstanding any other provision of this RFQ or any other document already issued or to be issued in future in connection with the Process, the Fund reserves, with the permission of the Ministry of Territorial Administration and Infrastructure of RA, the right at all times:

- a. To reject Prequalification Applications from Prospective Bidders from countries with which Republic of Armenia does not have diplomatic relations;
- b. To vary the capacity of the Project being procured under the Process;
- c. To amend the Process or amend or clarify the procedures and rules relating thereto;
- d. To extend or amend the Estimated Timetable from time to time;
- e. To terminate the Process; and
- f. To request additional information from any Prospective Bidder reasonably required to assess this Prequalification Application,

in each case at any time and for any reason and without incurring any liability to any Prospective Bidder or Prequalified Bidder in respect thereof.

## **6.6. Governing Law**

The Process will be governed by the laws of the Republic of Armenia.

## Appendix 1: Background Information

### 1. Power Sector in Armenia

- 1.1. The power system is unbundled and consists of independent electricity generation, transmission, and distribution companies as well as the electric power system operator (EPSO) and the settlement centre. The power system is regulated by an independent regulatory agency – the Public Services Regulatory Commission (PSRC). The regulatory framework is overall adequate with tariff-setting methodology allowing for cost-recovery. Presented below is the summary description of key entities in the power sector and their responsibilities.

Figure 2: Power Sector Structure

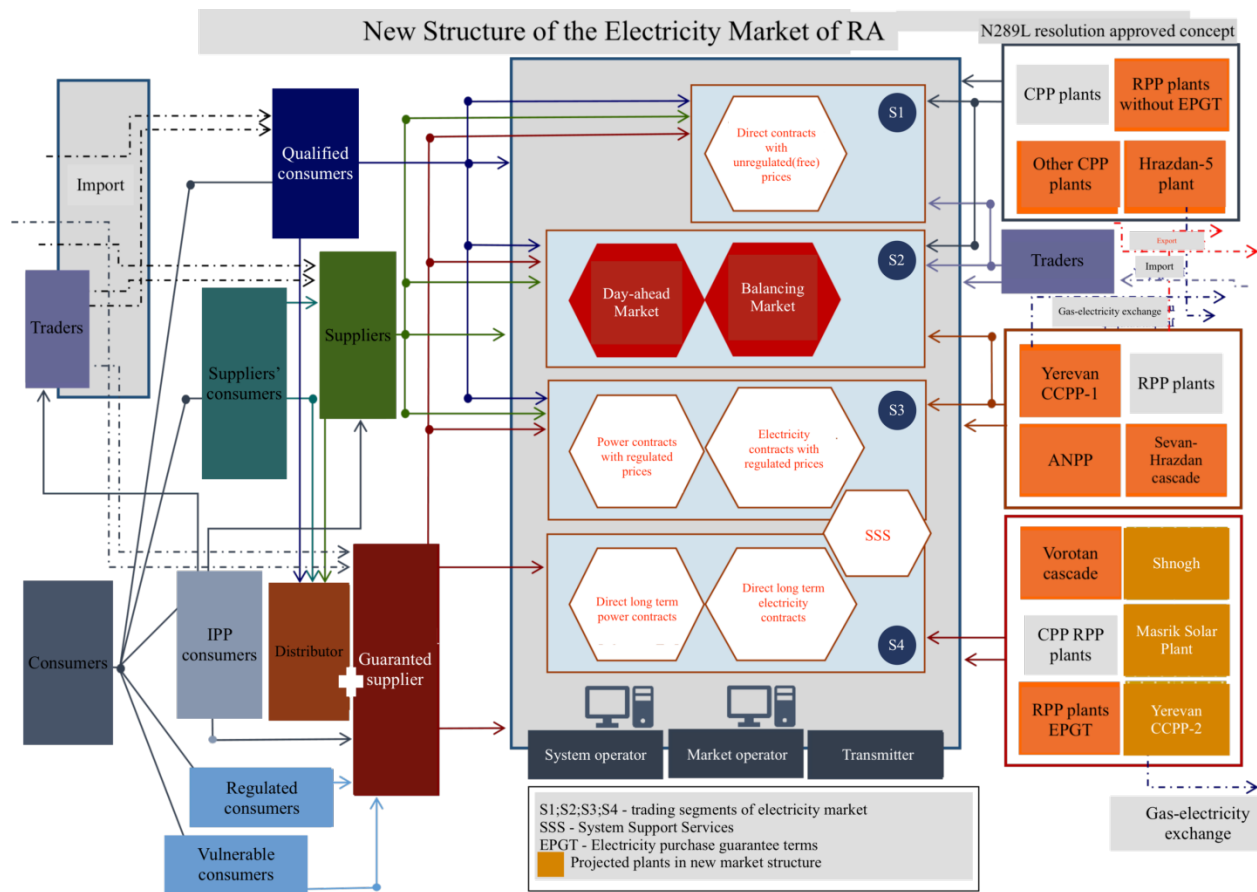

Source: Appendix: RA Public Services Regulatory Commission Decision No.289L of July 18, 2018

## Wholesale market participants

1. Electricity producers that will be classified in the following groups for at least seven years.
  - a. Electricity producers that are subject to tariff regulation and can operate at competitive prices (hereinafter-**RPP**), in particular, Armenian Nuclear Power Plant (hereinafter-ANPP), Yerevan Combined Cycle Co-generation Power Plant, Unit-1 (YCCPP-1), "Hrazdan Energy Company (RazTES)" OJSC, Hrazdan thermal power plant (hereinafter-Hrazdan TPP), Sevan-Hrazdan cascade of hydroelectric power plants.
  - b. Electricity producers, operating under PPP /Public private partnership/ agreements and being exclusively subject to tariff regulation (hereinafter-**APP**), in particular, Vorotan cascade of hydro power plants, Yerevan Combined Cycle co-generation Power Plant, Unit-2 (YCCPP-2), "Masrik-1" solar power plant, "Shnogh" hydroelectric power plant.
  - c. Small hydropower plants (up to 30 MW) and electricity producers which use other renewable energy sources (hereinafter **REP**), have electricity purchase guarantee according to the "Law on Energy" of the RA, (based on the recent data, it is expected that 191 plants will be built by 2020 with a total capacity of 360 MW and an average annual production of 1035 GWh).
  - d. Producers which produce electricity at full competitive prices in the market (hereinafter-**CPP**), "Hrazdan -5" of "Gazprom Armenia" CJSC, generating electricity in combined steam turbine/gas turbine technology (hereinafter "Hrazdan-5"), although tariff is currently regulated, such regulation is based on the principle of accepting "Hrazdan TPP" tariff as a limit value, consequently, "Hrazdan-5" de facto is operating under the market-based pricing mechanism, de jure being in tariff regulation. Complete removal of "Hrazdan-5" from tariff regulation will significantly contribute to the market development. This group also involves REP plants, for which electricity purchase guarantee has been expired as stipulated by the "Law on Energy" of the RA, (according to current data, there will be 27 plants with a total capacity of 56 MW and an average annual production of 156 GWh by 2020), and other producers at unregulated (free) prices (currently two small cogeneration plants generate thermal energy).

Actually, **CPP** plants will be the first to function in the fully competitive market. The new market structure and trading mechanisms are aimed at ensuring access to the market of new **CPP** plants and attracting private investments. However, this does not mean that only **CPP** plants will be able to sell electricity in competitive conditions. **RPP** plants will also be free to sell electricity at unregulated (free) prices after fulfilling their contractual obligations in the regulated sector of the wholesale market. It is also possible that ANPP and "YCCPP-1" will have surplus not in demand in the regulated segment of energy market and will be able to sell electricity at unregulated

(free) prices in certain situations. All this will depend on the growth in demand, structure and change of the plant's mode of operation, as well as on the autonomy given to the RPP plants by market rules.

2. Guaranteed supplier whose role will be undertaken by the Distributor-ENA during the first seven years and who will remain fully regulated in the regulatory field as a guaranteed supplier. Guaranteed supplier will be allowed to buy electricity in the wholesale market, import it and sell the surplus to other market participants according to the procedures established by the market rules. Guaranteed supplier will continue to provide payments for the electricity (capacity) purchased in the wholesale market with a special account mechanism established by the temporary trading rules of the wholesale electricity market, approved by the Commission Decision No344N of August 9, 2017.
3. Suppliers that are not active in the electricity market of the Republic of Armenia now and are expected to enter gradually after the entry into force of the Law on "Amendments and Supplements in the "Law on Energy" of the Republic of Armenia" dated February 7, 2018, HO-100-N and transition into a liberal market structure. Suppliers will be allowed to buy electricity in the wholesale market and from the Independent power producers (IPP), import it, and sell the surplus to other market participants according to the procedures established by the market rules. The latter will be obliged, in accordance with the contract model forms set by the Commission, to supply electricity to consumers who have concluded supply contracts with them.
4. 1) Traders with the characteristic functions are currently represented only by one state-owned company ("Energoimpex" CJSC) with a license to import electricity. It is expected that in parallel with the market development, new private traders will also appear. Traders will be entitled to buy electricity from producers and other participants of the wholesale market at unregulated (free) prices, export it, as well as import and sell it on the wholesale market according to the procedures defined in the market rules. In this context, it should be noted that the right to export electricity will be granted only if the domestic demand for energy consumption is met, the criteria of its definition should be described in the market rules.
5. Qualified consumers will be allowed to buy electricity in the wholesale market, import it or sell the surplus to other market participants pursuant to the procedures of the market rules, in accordance with the Law on "Amendments and Supplements in the "Law on Energy" of the Republic of Armenia", dated February 7, 2018, HO-100-N. Any consumer will be able to obtain a status of a qualified consumer on the basis of its own application, if the criteria set by the market rules are met. Currently, according to the temporary trade rules of the wholesale electricity market, only consumers connected to a distribution network with a voltage of 6 (10) kV and higher can become a qualified consumer if their commercial accounting system meets the criteria specified by the network rules of the power system approved by the Commission Decision No161n of



May 17, 2017, and is registered by the market operator. Although this scope is already quite extensive, it can be gradually expanded to include all commercial consumers at all voltage levels.

6. Independent power producer consumers (hereinafter IPP consumers), which are legal entities or individuals producing electricity to meet their own needs, and are actually consumers. At the same time, installed capacity of the IPP consumer should not exceed total installed capacity of its electricity consumers, but no more than 150 kW. Electricity production by IPP consumer with an installed capacity of 150 kW is not regulated during the production period; in case of solar plants it is not regulated during the construction period as well. Therefore, it is allowed to install solar plants by IPP consumers with a capacity of up to 500 kW instead of 150 kW until January 1, 2022. According to the "Law on Energy Saving and Renewable Energy" of the RA, amounts due against the electricity supplied by IPP consumers to ENA and vice versa is calculated on a monthly basis, final calculation is made on an annual basis. In fact, IPP consumers have an opportunity to "store" surplus electricity at ENA and consume it when their own demand is higher than that of the plant. Final balancing of consumed and additionally supplied electricity to the distribution network is carried out according to annual results. When consumption exceeds production, the IPP consumer pays for it according to the tariffs established by the Commission; otherwise ENA pays that IPP consumer in the amount of the statutory compensation set for that plant. These mechanisms have mostly been improved and consolidated over the past two years. All the above-mentioned tools contain quite serious incentives for the development of IPP consumers, and as of April 1, 2018, about 306 IPP consumers with a total capacity of 3.4 MW are already operating in the Republic of Armenia. In accordance with the Law on "Amendments and Supplements in the "Law on Energy" of the Republic of Armenia" dated February 7, 2018, HO-100-N, IPP consumers will retain right to "store" electricity to an already guaranteed supplier on the same terms, and also sell to suppliers or traders, freely participating in both wholesale and retail markets.

#### **Wholesale market service providers**

1. The system operator will be granted an exclusive right and will require market participants to provide services to short-term planning and dispatch, operational management of the power system, planning the development of electricity transmission network and ensuring parallel operation of power system of the Republic of Armenia with power systems in the region. In addition, the system operator will be entitled to perform other non-exclusive functions provided for in the license terms and market rules. The system operator will be obliged to take all necessary measures to ensure electricity generation and transmission with minimal expenses, taking into account electricity purchase guarantees stipulated by the "Law on Energy" of the Republic of Armenia or obligations undertaken by the Government of the Republic of Armenia under the PPP agreements.
2. Market operator who will be granted the exclusive right and will be obliged to provide the following services to market participants.

- a. consolidating electricity market activities ,
- b. registering participants of electricity market,
- c. keeping records of agreements between the participants of the wholesale market and electricity (capacity) export and import contracts,
- d. recording/computing electricity (capacity) purchased and sold under contracts concluded in the power market, as well as in the scope of export and import agreements, preparation of documents and submission to commercial participants and service providers of wholesale market,
- e. rights to perform other non-exclusive functions under the license terms and market rules,

Market operator together with other licensed entities shall develop trading rules for electricity wholesale and retail market for the submission to the Commission for approval. Any competitive procurement, purchase of electricity, capacity and system support services should be carried out through the market operator.

3. Transmitter is currently the "High Voltage Electricity Networks" Closed Joint-Stock Company (hereinafter HVEN), which operates under the full control of the System Operator. According to the "Law on Energy" of the Republic of Armenia, transmitter is entitled to provide electricity (capacity), to build (reconstruct) transmission network in the territory of the Republic of Armenia. The transmitter is obliged to perform its functions in accordance with the market rules and concluded contracts. Relations between the transmitter, system operator, market operator and wholesale market participants will be governed by the market rules and agreements.
4. Distributor is currently ESA that provides services to those wholesale market participants who are connected to the distribution network. Distributor will continue to provide services in accordance with market rules and concluded contracts.

### **Retail market participants**

- 1.1. Guaranteed supplier that will be completely within the scope of regulation of the Commission and will supply electricity to all consumers who do not use suppliers' services, or supplier does not supply electricity for reasons beyond the control of this consumer. These consumers may consist of vulnerable consumers who are not able to choose another supplier. The guaranteed supplier and its consumers will conclude supply contracts in accordance with the model contract form defined by the Commission.

Suppliers that will gradually enter the retail market after the entry into force of the "Law on Amendments and Supplements in the "Law on Energy" of the Republic of Armenia" dated February 7, 2018, HO-100-N and transition into a liberalized market structure, making possible retail competition.

Retail Market Service Provider is the Distributor- ENA, which will continue to operate as a sole distribution entity throughout the territory of the Republic of Armenia providing its services to retail market participants and remaining fully in the Commission's regulatory field, pursuant to the "Law on Energy" of the RA, to carry out licensed activities for the electricity distribution under the terms of the license, as well as market rules and contracts concluded.

- 1.2. The PSRC is responsible for overall power sector regulation, including tariff-setting for electricity generation, transmission, and distribution companies as well as end-users. Except for small renewable energy plants (with installed capacity of less than 30MW), which have feed-in tariffs, and tariffs for PPP transactions, all other generation companies are set following the “rate or return” methodology. Under this regime, the revenue that the generation, transmission, and distribution companies are allowed to cover include: (a) eligible costs related to licensed activities such as fuel, operation and maintenance, repairs; (b) asset depreciation; (c) taxes and other fees; and (d) an allowed return on invested capital. The return allowed on invested capital is based on the estimated WACC. The tariffs are computed in local currency.
- 1.3. There are no explicit or implicit subsidies in the power sector, strong payment discipline for consumed electricity, and complete pass-through of all costs to end-user tariffs. The electricity bill collections were at 100% of sales starting from 2003.
- 1.4. The costs in each segment of the value chain for electricity supply are fully passed through to end-user tariffs given the below key mechanisms in place.

## **2. Power Sector Demand and Supply Balance**

- 2.1. The country currently has sufficient generation capacity (including reserve margin) to meet the peak load. Going forward, new generation capacity will need to be built to meet the forecast peak load. The need for new capacity is driven by the forecast domestic demand, exports, and the need to decommission the inefficient generation units 1-4 of Hrazdan TPP. Presented below is the forecast of the peak load and capacity shortage, which are expected to increase. The assessment is based on the available generation capacity, planned additions of new capacity (such as small hydropower plants and incremental supply from Armenian Nuclear Power Plant after completion of the rehabilitation) and planned retirement of existing assets such as Hrazdan TPP old units. The peak load is assumed to increase at the same rate as the forecast average annual growth rate of total energy demand (2.2% per year based on forecast GDP growth rates and annual tariff increases). The reserve margin is determined as per N-1 reliability criteria and is assumed to equal to the largest unit in the power system, which is the 440MW new 5<sup>th</sup> unit of Hrazdan TPP. The firm supply capacity for hydropower plants was estimated taking deterministic approach and based on observed average historical generation figures. The firm capacity of thermal power plants and the nuclear power plant was estimated as the available generation capacity to meet peak load.

**Figure 1: Peak Load and Firm Capacity Forecast**

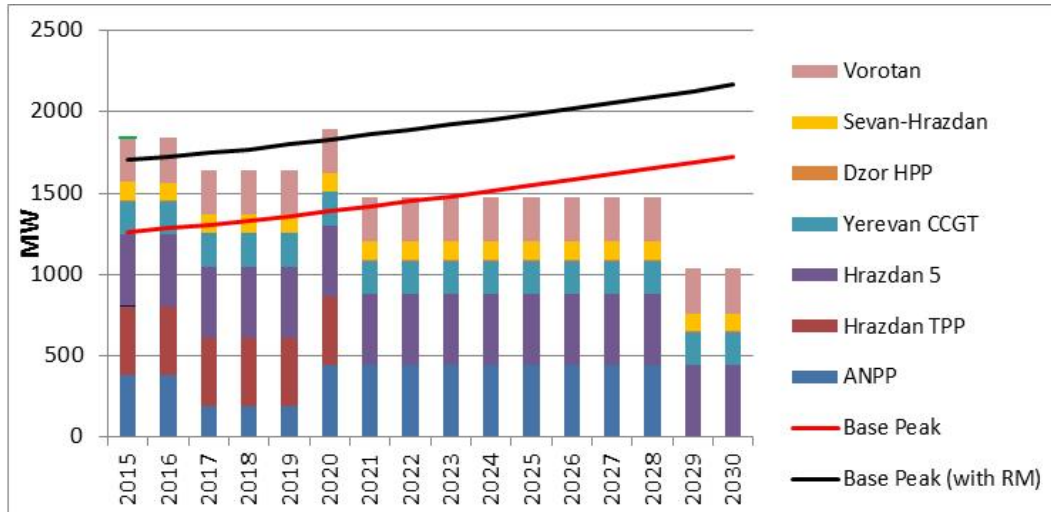

Source: Fund's Consultant Estimate.

## Appendix 2: Minimum Technical Requirements

The following technical requirements relating to the PV Modules, Inverters and Mounting Structures should be noted by bidders:

### PV Modules

The PV modules shall have valid test reports issued by reputable qualified testing institutions (ISO 17021/ ISO 17025 and ISO 17065 certified) for the latest edition of following IEC / UL for PV module qualification test or equivalent standards.

Without prejudice to meeting the minimum qualification criteria, bidders are encouraged to submit test results relative to third-party measured, extended accelerated module testing such as offered by qualified testing institutions such as TÜV, UL, KIWA, Intertek, NREL or DNV-GL. These include but are not limited to Thresher test, Reliability Demonstration, Long Term Sequential (LTS), Photovoltaic Durability Initiative (PVDI) testing sequence, or PV Module Qualification Plus.

**IEC 61215.** Crystalline silicon terrestrial photovoltaic (PV) modules - Design qualification and type approval.

**IEC 62108. Concentrated (PV) modules** - Design qualification and type approval.

**IEC 61853** - Part 1: PV module performance testing and energy rating.

**IEC 61730.** PV module safety qualification.

**IEC 60364-4-41.:** Protection against electric shock.

**IEC 61701.** Resistance to salt mist and corrosion.

**IEC 60904.** Photovoltaic devices.

**IEC 62804.** Potential Induced Degradation (PID).

**IEC 61345.** UV test for Photovoltaic (PV) modules.

**EN 50380.** Datasheet and nameplate information for photovoltaic modules.

**Conformité Européenne (EC):** The certified product conforms to the EU health, safety and environmental requirements.

- **UL 1703.** These requirements cover flat-plate photovoltaic modules and panels intended for installation on or integral with buildings, or to be freestanding (that is, not attached to buildings), in accordance with the National Electrical Code, NFPA 70, and Model Building Codes.

### Modules Technical Specifications:

- The PV modules shall have a minimum efficiency at Standard Test Conditions of 19%.
- The nominal power tolerance of modules shall be within 0/+3%.
- PV modules must be warranted for output wattage, this should not be less than 90% at the end of 10 years and 80% at the end of 25 years.

Quality Assurance Plan: Bidders shall provide a comprehensive PV module quality assurance plan, which may include testing at the factory location or factory inspection by a qualified testing institution.

All PV modules shall be of the same type and from manufacturer (s) conforming to the following requirements:

- Supply of at least 500 (Five hundred) MWp PV Module capacity between January, 2018 – December, 2019.
- The PV modules shall have been installed in at least four different projects in the past two years, in at least three different countries, in each case financed on a non-recourse or limited recourse basis;
- PV Module manufacturing facilities certified according to:
  - ISO 9001 – Quality Management Systems; and
  - ISO 14001 – Environmental Management Systems.

### **Inverters**

The inverters must have a minimum Euro efficiency of 98%, a product warranty of at least 10 years, and a guarantee against manufacturing defects of at least 5 years.

The inverter shall be either (i) indoor type and located inside an inverter room or (ii) a proven outdoor type with a minimum protection rating of IP65. If outdoor type, the inverters are to be provided within an inverter station designed to withstand at least 45°C of external ambient temperature.

All inverters shall be of the same type, from a single manufacturer and shall have been installed in at least three different projects in the past two years, in each case financed on a non-recourse or limited recourse basis. The manufacturer shall conform to the following requirements:

- Five-year manufacturing history;
- >3000 MW global installed capacity;
- >500 MW/year manufacturing capacity;
- Inverter manufacturing facilities certified according to:
  - ISO 9001 – Quality Management Systems; and
  - ISO 14001 – Environmental Management Systems.

### **PV Module Mounting Structure**

The PV module mounting structure shall be either fixed or single-axis tracking. The design and construction of the mounting structure shall take into account the following:

- If tracking technology is used, the tracking system must have been installed in at least three different projects, each of capacity at least 25 MWac, in the past two years. In addition, the tracking system should have a warranty of at least 5 years.

- Structural supports shall be manufactured to withstand high levels of corrosion by using anodized aluminium or hot-dip galvanised steel, bolts and screws.
- Piles (if any) shall be constructed of either steel or concrete. If steel is specified, the piles shall be manufactured to withstand increased anticipated levels of corrosion by using hot-dip galvanised steel.
- The mounting system shall have a ten-year latent defect warranty.

## **220 MW "Ayg-1" solar plant connection to power transmission network**

1. Solar plant will be connected to the power transmission network via 220 kV substation, and two 250MWcapacity transformers, the connection diagram of which is shown below.
2. Fiber-optic (OPGW) cables (36 fibers) are installed on 220 kV **Ashnak-1** and **Ashnak-2** overhead power lines. To connect to the network via access-exit scheme, it is necessary to construct overhead power lines with a voltage of 220 kV (a length of about 300m), at the same time install cables of similar type.
3. Substation should be equipped with a SCADA system, which will be capable of providing certain information (active power, reactive power, voltage, shutdown and operation of devices, etc.).
4. The on-duty staff of the substation and the plant reports to the duty officer of the central dispatch center of "EPSO" CJSC according to the regulations of the Public Services Regulatory Commission.
5. For the purpose of quick connections/ operative communication, technological telecommunication will be provided by "EPSO" CJSC via fiber-optic channels.
6. The capacity and functions of relay protection and automation devices to be installed at the plant should be coordinated with "EPSO" CJSC.
7. Relay protection devices should be calculated and agreed with "EPSO" CJSC.
8. The power factor  $\cos\phi = 1$  should be specified by the manufacturer at the isolation/separation point of the plant.
9. The winner/ awarded bidder should apply to get technical requirements for the network connection in accordance with the network rules.
10. The plant design developed on the basis of given technical requirements should be agreed with "EPSO", "HVEN" and "Settlement Center" CJSCs.

### Ayg-1 Solar Plant Connection Diagram

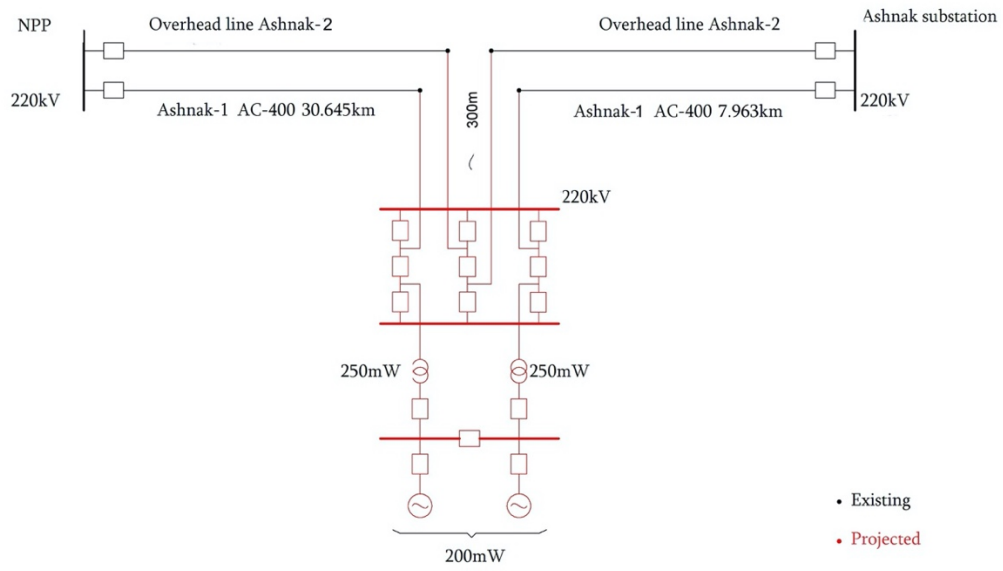



# Ayg-1 solar plant grid connection diagram

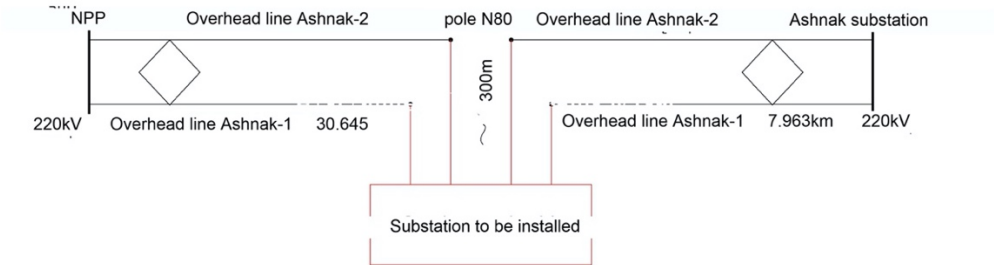

- Existing
- Projected

### Appendix 3: Background and Contact Details of Armenia Renewable Resources and Energy Efficiency Fund

The Fund was established by the Government of Armenia in 2006 as a non-government organization, has the mission to facilitate [investments](#) in energy efficiency and renewable energy in Armenia. The Fund is currently implementing the Investment Program under the Strategic Climate Fund’s Scaling-up Renewable Energy Program (SREP) in Armenia. The Investment Program foresees development of renewable energy technologies identified to have the largest potential for scale-up in the country at economically acceptable cost. One of the priorities in the Investment Program is development of the utility-scale solar photovoltaic (PV) plants.

<b>Project Name</b>	<b>Solar Armenia Utility-Scale Solar Power Project</b>
Fund contact details	Email: r2e2fund@gmail.com Attention: Solar Armenia Project
RFQ Participation Fee	US \$1,000
Wire transfer details for RFQ Participation Fee	<p><b>FOR USD</b> Beneficiary name:R2E2 FUND Beneficiary account 217001007855103 USD <b>Beneficiary Bank</b> HSBC Bank Armenia CJSC Yerevan, Armenia SWIFT address: MIDLAM22 <b>Correspondent Bank</b> HSBC Bank USA New York US SWIFT address: MRMDUS33</p> <p><b>FOR EUR</b> Beneficiary name:R2E2 FUND Beneficiary account 217001007855105 EUR <b>Beneficiary Bank</b> HSBC Bank Armenia CJSC Yerevan, Armenia SWIFT address: MIDLAM22 <b>Correspondent Bank</b> HSBC France SWIFT address: CCFRFRPP</p> <p><b>FOR AMD</b> Beneficiary name:R2E2 FUND</p>

	Beneficiary account 217001007855001 AMD BENEFICIARY BANK: HSBC Bank Armenia CJSC
Address for Submission and Opening of Prequalification Applications	
Prequalification Application language	English
Number of copies of Prequalification Application	Electronically / One original and five copies

## Appendix 4: Confirmation Letter

**To: Armenia Renewable Resources and Energy Efficiency Fund**

**Re: 200MW AC AYG-1 SOLAR PV PROJECT – REQUEST FOR PREQUALIFICATION**

[Date]

Dear Sir/Madam,

I refer to the Request for Prequalification document, dated \_\_\_\_\_, issued in connection with the Project (RFQ). Capitalized terms defined in the RFQ and used but not defined herein shall bear the meanings ascribed to them in the RFQ.

In accordance with section 5.4.3(a) of the RFQ, I hereby confirm on behalf of [*name of Prospective Bidder or Consortium Member*] (Company) that:

- (a) the Company and all Relevant Persons are not in bankruptcy or liquidation proceedings or receivership, or wound up, or their affairs are not being administered by a court or a judicial officer, or their business activities have not been suspended or they are not the subject of legal proceedings of any of the foregoing and have a reasonable expectation of being able to discharge all financial liabilities as they fall due;
- (b) neither the Company nor any Relevant Person has been convicted of fraud, corruption, collusion or money laundering or for a criminal act involving dishonesty, physical violence or harm to human life, or for any criminal offence related to their professional conduct within a period of five years of commencement of the procurement proceedings, nor is the subject of credible and/or persistent allegations related to, or is under investigation for, such criminal activities;
- (c) the Company is not aware of any conflict of interest or potential conflict of interest arising from prior or existing contracts or relationships which affects or could affect its or (upon formation) the Seller's (as applicable) potential involvement in the Project;
- (d) neither the Company nor any Relevant Person has any tax liabilities or outstanding social security contributions or liabilities in respect of judgments awarded by any court or similar proceedings in the period of three years prior to the date of this invitation, save in each case to the extent that it has made suitable accounting provision for such liabilities in accordance with applicable accounting regulations;
- (e) neither the Company nor any Relevant Person has previously been excluded from tender or other public procurement processes in the Republic of Armenia, and are not debarred or suspended from participation in public procurement tenders at their respective countries;

- (f) neither the Company nor any Relevant Person has had a concession or PPA terminated that is attributable to an event of default of the concessionaire in the event of a concession or a seller of power in the event of a PPA;
- (g) neither the Company nor any Relevant Person:
- is included as a debarred person pursuant on the public sanctions list of any multilateral development bank that is party to the Agreement on Mutual Enforcement of Debarment Decisions of 9 April 2010 ([www.crossdebarment.org](http://www.crossdebarment.org)); or
  - is included on any sanctions lists promulgated by the UN Security Council or its Committees, or any other recognized international sanctions list; and
- (h) neither the Company nor any Relevant Person has operations (directly or through any subsidiary) or carries out transactions that are not in compliance with the sanctions promulgated by the UN Security Council or its Committees or national sanctions in Republic of Armenia.

In accordance with Section 5.4.3 of the RFQ, I enclose the following documents:

- (a) a comprehensive organization chart showing – or narrative text describing – how the Company is owned, up to the level of ultimate beneficial ownership by individuals and identifying by name all legal or natural persons holding (at any level in the organization structure) an aggregate ultimate beneficial interest of at least 5%;
- (b) certified copies of up-to-date constitutional documents of the Company; and
- (c) a power of attorney substantially in the form attached as Appendix 5 of the RFQ and otherwise meeting the requirements of section 5.4.3(d) of the RFQ.

Yours faithfully,

---

[Name]

[Position]

Authorized to signatory for [*Prospective Bidder or Consortium Member*]

## Appendix 5: Legal Qualification – Power of Attorney

Reference is made to Solar Armenia Project (Project) and the Request for Prequalification document, dated [RFQ Issuance Date] issued in connection therewith (RFQ). Capitalized terms defined in the RFQ and used but not defined herein shall bear the meanings ascribed to them in the RFQ.

[Company], incorporated under the laws of [country] and having its registered office at [address] (Company) does hereby irrevocably constitute, nominate, appoint and authorize [name]<sup>5</sup> of [address], who is presently employed with [Consortium Leader] and holding the position of [title], as its true and lawful attorney (Attorney) to do in its name and on its behalf, all such acts, deeds, matters and things as are necessary or required in connection with or incidental to submission of a Prequalification Application on behalf of [Prospective Bidder] pursuant to the RFQ issued and for the ensuing participation of [Prospective Bidder] as Prequalified Bidder including but not limited to:

- (a) Representing the Company [and the Prospective Bidder] in all matters relating to the Process, including signing, executing and submitting all bids, proposals, contracts, undertakings and other documents relating to the Process (including the Project Agreements);
- (b) Participating in pre-bid conferences and other conferences and providing information/responses to the Fund and generally dealing with the Fund in all matters in connection with or relating to the Process,

and we hereby agree to ratify and confirm and do hereby ratify and confirm all acts, deeds, matters and things done or caused to be done by our said Attorney pursuant to and in exercise of the powers conferred by this Power of Attorney and that all acts, deeds and things done by our said Attorney in exercise of the powers hereby conferred shall be done and shall always be deemed to have been done by us.

A specimen signature of each Attorney is attached to Schedule 1 of this Power of Attorney for reference.

IN WITNESS WHEREOF, THE COMPANY HAS EXECUTED THIS POWER OF ATTORNEY ON THIS ..... DAY OF ....., 20..<sup>6</sup>

BY .....

---

<sup>5</sup> In the case of a Consortium, all Consortium Members should appoint the same individual, who should be an employee, officer or other representative of the Consortium Leader.

<sup>6</sup> Execution formalities should be adjusted as required for the country of incorporation / constitutional documents of the Prospective Bidder / Consortium Member (e.g., as regards notarization / apostille, etc.). However, no substantive changes should be made unless they have first been cleared with the Fund.

**Schedule 1 – Specimen Signatures**

Attorney Name: .....

Specimen Signature: .....

*[repeat for each Attorney as required]*

## Appendix 6: Prequalification Form

**To: Renewable Resources and Energy Efficiency Fund**

**Re: 200MW AC AYG-1 SOLAR PV PROJECT – REQUEST FOR PREQUALIFICATION**

[Date]

Dear Sir/Madam,

1. I refer to the Request for Prequalification document, dated [RFQ Issuance Date], issued in connection with the Project (RFQ). Capitalized terms defined in the RFQ and used but not defined herein shall bear the meanings ascribed to them in the RFQ.
2. [Prospective Bidder] hereby submits its Prequalification Application in conformity with the RFQ and requests to be considered for prequalification as a Prequalified Bidder in connection with the Project and confirms that it:
  - a. Acknowledges and agrees to the disclaimer in and other terms of the RFQ;
  - b. Agrees to comply with all rules, laws and regulations governing the Process as issued by the Fund and any other relevant authorities from time to time; and
  - c. Accepts the right of the Fund:
    - (i) to vary the capacity of the Project;
    - (ii) to amend the Process or amend or clarify the procedures and rules relating thereto;
    - (iii) to extend or amend the Estimated Timetable from time to time;
    - (iv) to terminate the Process; and
    - (v) to request additional information from any Prospective Bidder reasonably required to assess this Prequalification Application,in each case at any time and for any reason and without incurring any liability to any Prospective Bidder or Prequalified Bidder in respect thereof; and
  - d. accepts the exclusive application of the laws of Armenia with respect to the Process.
3. [Prospective Bidder] hereby designates the Attorney identified (and as defined) in the Power of Attorney enclosed within this Prequalification Application as its representative to



receive notices in respect of the prequalification and the tender at the following address, telephone numbers and email address:

*[Details]*

4. *[Prospective Bidder]* hereby confirms that the Power of Attorney enclosed within this Prequalification Application is legal, valid, binding and enforceable in accordance with its terms.
5. *[Include one of the following two provisions, depending on whether the Prospective Bidder is a Consortium (first provision) or a single entity (second provision):]*
  - *Prospective Bidder]* confirms that it is a Consortium comprising the following Consortium Members: *[List Consortium Members, clearly identifying the Consortium Leader, and set out each Consortium Member's anticipated ultimate beneficial shareholdings in the Project Company]*. *[Prospective Bidder]* confirms that there will be no change in the membership of the Consortium or the foregoing anticipated beneficial shareholdings in the Seller (or related control and other interests held) by each Consortium Member (Anticipated Project Company Ownership) until signature by or novation to the Seller of the Project Agreements and then only as permitted therein, save to the extent that the Fund otherwise consents in writing.
  - *[Prospective Bidder]* confirms that it is submitting this Prequalification Application in its own right and not as a Consortium, that it anticipates holding the entire beneficial shareholding in the Seller (and related control and other interests) (Anticipated Seller Ownership) and that there will be no change in the Anticipated Seller Ownership until signature by or novation to the Seller of the Project Agreements and then only as permitted therein, save to the extent that the Fund otherwise consents in writing.
6. *[Only include if the Prospective Bidder is a Consortium comprising at least one Consortium Member that is not a Consortium Leader:*

*[Prospective Bidder]* hereby confirms that, in the event that it is awarded the Project, the Consortium Leader will jointly and severally cover any shortfall in the equity contribution of any Consortium Member that is not a Consortium Leader.]

7. *[Prospective Bidder]* hereby represents and warrants that as of the date of this letter all of the information submitted in this Prequalification Application, including the enclosed forms and documents, is accurate, complete and not misleading in any respect.

Yours faithfully,

---

Attorney for *[Prospective Bidder]* under enclosed Power of Attorney

## Appendix 7: Terms of the Project Company Founding Agreement

### HEADS OF AGREEMENT (HOA) FOR A PROJECT COMPANY FOUNDING AGREEMENT (FA) Ayg-1 Solar PV 200MWac PROJECT

<b>Parties</b>	[●] and the <b>Armenian National Interests Fund</b> , a closed joint-stock company established on May 20, 2019 by the Government of the Republic of Armenia, as a state-owned company, located at Melik Adamyant Street 2/2, Yerevan, Republic of Armenia, 0010, with registration number 286.120.1075203, TIN: 02697868 ("ANIF")
<b>Business</b>	The primary business activities of the Company shall be the development, construction, operation and maintenance of Ayg-1 Solar PV 200MWac PROJECT in the Republic of Armenia (the Business).
<b>Incorporation</b>	The Company will be incorporated as a joint stock company under the laws of the Republic of Armenia. It is anticipated that the initial issued share capital of the Company shall be Dram [equal to USD 1,5 million] divided in [●] ordinary (common) shares of [●] ([●]) AMD each.
<b>Shareholding</b>	Shares in the Company shall be owned among the Parties in the following percentages: i) [●] shall hold 85% ([●] shares); and ii) ANIF shall hold a 15% ([●] shares).
<b>ANIF's Shareholding</b>	ANIF will contribute 15% equity in the Project Company by local partnership. ANIF's 15% shareholding will be provided in the form of zero-interest loan. The loan must be provided upon the incorporation of the Project Company and is payable until the end of the Project. ANIF will also be provided a zero-interest loan in the amount of 15% of share capital upon signing of this HOA. ANIF will have a right to pay the loan back until the end of the Project.
<b>Payment for Company Shares</b>	Company shares should be paid in AMD at the time of the Company's incorporation.
<b>Board</b>	The Parties shall be entitled to appoint members to the Board of Directors (the Board) of the Company in proportion to their share interest. The Board shall meet as necessary to discharge its duties but in any case, no less frequently than four times per year, unless decided otherwise by the Board. Each director shall have one vote on resolutions put to the

	Board. All resolutions of the Board, save for resolutions in relation to certain reserved matters detailed in the shareholders agreement between the Parties, shall be decided by a simple majority of those directors attending the meeting and entitled to vote, unless otherwise required by applicable law. The Directors shall be entitled to appoint a proxy to represent them and vote at any meeting.
<b>Employees</b>	The Parties shall provide to the Company such qualified and experienced employees of each party as the Company may reasonably require achieving its objectives.
<b>Business Plan</b>	The FA shall contain an approved initial business plan and budget. The business plan shall be reviewed and approved by the Board at regular intervals and updated at least annually.
<b>Region</b>	The Company's operations shall be initially focused on the geographical area of the Republic of Armenia.
<b>Intellectual Property Rights</b>	Each Party acknowledges that the other party may have pre-existing intellectual property rights (i.e. rights that existed prior to the date of the FA), and that such rights are vested, and shall remain vested, in the party having such rights.
	The Parties acknowledge that the Company may create certain additional intellectual property during the existence of the Company, and such rights shall be owned by the Company and may not be shared, licensed or provided to any third parties without the express written consent of the Company.
<b>Representations &amp; Warranties</b>	Customary representations and warranties to be contained in the FA , including: due incorporation and valid existence; power and authority to enter into and perform obligations under the FA; all necessary consents, licences and approvals to enter into the FA; and the entry into and performance of the FA will not conflict with any law, constitutional documents or any other agreements.
<b>Share transfers</b>	Save as provided below or in connection with a government restructuring, no Party shall be entitled to transfer or otherwise dispose of all or any of its shares in the Company without first offering them for transfer to the other Party.  A Party may transfer all of its shares in the Company to a person or entity subject to the prior written approval of all the other Parties.

<b>Costs</b>	Each Party will bear the costs incurred by it in relation to the preparation, negotiation and execution of this HOA and the cost of drafting and negotiating the FA.
<b>Confidentiality &amp; Announcements</b>	<p>Each of the Parties shall keep confidential and shall not disclose to any other person, nor use for any purpose except the purposes of the Business, any information obtained from the other Party as a result of negotiating, entering into or implementing this HOA and the FA other than information which:</p> <ul style="list-style-type: none"> <li>is required to be disclosed by operation of law or any stock exchange regulations or any binding judgment or order, or any requirement of a competent authority;</li> <li>is reasonably required to be disclosed in confidence to a Party's professional advisers for use in connection with the SHA and/or matters contemplated herein; and</li> <li>is or becomes within the public domain (otherwise than through the default of the recipient Party).</li> </ul>
<b>Deadlock</b>	<p>A deadlock event shall be deemed to have occurred in any of the following circumstances:</p> <ul style="list-style-type: none"> <li>(a) failure of the shareholders to agree on any matter requiring their consent pursuant to the FA, the Company's constitutional documents or as a matter of law;</li> <li>(b) failure of the Board to agree on a reserved matter or other matter material to the business; and</li> <li>(c) no quorum is obtained at three consecutive Board meetings.</li> </ul>
	<p>A deadlock event shall be resolved in accordance with the following escalation procedure:</p> <p>If a deadlock event occurs and cannot be resolved by the shareholders within 30 days of the event which has resulted in a deadlock event, the matter may be referred by either shareholder to the chief executive officers of each shareholder.</p>
<b>Default</b>	<p>The following events shall be deemed to be events of default under the FA:</p> <ul style="list-style-type: none"> <li>(a) serious or persistent default in performing any of the shareholder's obligations under the FA;</li> <li>(b) the insolvency or liquidation of any shareholder; or</li> <li>(c) any shareholder attempts to deal with shares in the Company in contravention of the share transfer restrictions set out in the FA.</li> </ul> <p>The non-defaulting shareholder may, but shall not be obliged, to either (i) acquire the shares of the defaulting</p>

	shareholder at fair market value (as determined by an investment banker) less a discount of 10% or (ii) require the defaulting shareholder to purchase all of its shares at fair market value plus 10%.
<b>Dispute Resolution</b>	Any dispute or difference of any kind between the Parties in connection with or arising out of this agreement or the breach, termination or validity hereof (a Dispute) shall be finally settled by the Arbitration Institution at the Chamber of Commerce and Industry of the Republic of Armenia under the rules of the latter (the Rules).
<b>Governing Law</b>	This HOA and the FA shall be governed and construed in accordance with the laws of the Republic of Armenia.