



FEASIBILITY STUDY 19.4MWp MASRIK 2 PV PLANT VARDENIS, GEGHARKUNIK MARZ (ARMENIA)

Project number **PEF2827-118-Masrik 2-FS-R02-IBS-170420**

Prepared by **AF Aries Energía, S.L.**
April 2017



Document Revisions

Version	Date Approved	Approved by	Document Name	Brief Description
0.00	25/10/2016	Manuel Ladrón de Cegama		Feasibility Study
1.00	17/10/2016	Manuel Ladrón de Cegama		Feasibility Study
2.00	20/04/2017	Manuel Ladrón de Cegama		Feasibility Study



Content

1	EXECUTIVE SUMMARY	3
2	CODES AND STANDARDS.....	3
3	SITE LOCATION.....	5
4	GENERAL DESCRIPTION.....	6
5	SOLAR RESOURCE ANALYSIS	8
6	ENERGY YIELD ASSESSMENT	10
6.1	Model inputs and assumptions.....	10
6.2	Glossary of terms	11
6.3	Performance results	13
7	INSTALLATION DESCRIPTION.....	14
7.1	Generating System	14
7.2	Modules	15
7.3	Inverters	15
7.4	Combiner boxes or junction boxes.....	16
7.5	Generation Medium voltage transformers.....	16
7.6	Auxiliary Medium voltage transformers	17
7.7	Low voltage Cable.....	18
7.7.1	DC Cable 1	18
7.7.2	DC Cable 2	19
7.7.3	AC Cables	20
7.8	MV AC Cable.....	20
7.8.1	MV cables for PV Plant.....	20
7.9	Switchgears	21
7.9.1	ITC Switchgears	21
7.9.2	CC Switchgears	22
7.10	Grounding General Description	22
7.10.1	Grounding Conductors.....	22
7.10.2	Grounding Rods.....	23
7.11	Auxiliary Services	23



7.12	Essential Services	23
8	EVACUATION POWER LINE	24
8.1	General Summary	24
8.2	Technical Description.....	24
8.2.1	Base scope	24
8.3	Line route description.....	25
8.4	Electrical Characteristics of 110 KV Transmission Lines	25
8.5	Minimal clearance distance.....	25
8.5.1	Clearance distance between live part and the tower	25
8.5.2	Clearance distances between live part and ground or other elements	26
8.5.3	Clearance distance between phases	26
8.6	Foundations.....	26
8.6.1	Types and Choice of Foundations for Lattice Steel Towers	28
8.7	Towers.....	28
8.7.1	Standard Height of Towers.....	28
8.7.2	Minimum Ground - Live Conductor Clearances.....	29
8.7.3	Minimum Tower - Live Conductor Clearances	29
8.7.4	Typical span.....	29
8.8	Tower Accessories	29
8.9	Earthing.....	29
8.9.1	Installation of earthing	29
8.10	Technical characteristics of the phase conductors.....	30
8.11	Insulator Characteristics	31
8.12	Fitting Types.....	32
8.12.1	General information	32
9	SURVEILLANCE SYSTEM	33
10	MONITORIZATION SYSTEM.....	35
10.1	Description	35
10.2	Equipment	36
10.2.1	Meteorological station	37
11	CIVIL WORKS DESCRIPTION.....	39
11.1	Earth movements	39
11.2	Roads	40



11.2.1	Perimeter road	40
11.2.2	Internal road.....	40
11.2.3	Parking area	40
11.3	Buildings.....	40
11.3.1	Control Center.....	40
11.3.2	Warehouse	40
11.3.3	Inverter transformer center (ITC)	41
11.3.4	Connection center (CC)	41
11.4	Structure of photovoltaic modules.....	41
11.5	Foundations.....	42
11.5.1	Photovoltaic structure	42
11.5.2	CC facilities.....	43
11.5.3	ITCs, Control building and Warehouse foundations.....	44
11.6	Drainage	45
11.7	Perimeter fence	45
11.8	Water system	45
12	COST ESTIMATION.....	46
13	FINANCIAL ASSESSMENT	50
13.1	Introduction	50
13.2	Key assumptions	50
13.3	Energy volume data projections	51
13.4	Projections of capital investment costs and financing	51
13.4.1	Project investments and cost estimates (CAPEX)	51
13.4.2	Financing of project investments	52
13.5	Projections of Operational Costs.....	54
13.5.1	OPEX	54
13.6	Tariffs, revenue projections, I/S and Cash-Flow	54
13.6.1	Tariff calculation scenarios	54
13.6.2	Revenue projections.....	54
13.6.3	Projections of I/S.....	55
13.6.4	Cash flow projections	56
13.7	Financial Scenarios	56
13.7.1	Sensitivity Analysis	57
13.8	Conclusions and recommendations.....	59
14	DRAWINGS	60



15 ANNEXES 61

© Copyright Af Aries Energia

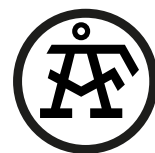

List of figures

Figure 1 – Site location (Source: Google Earth).....	5
Figure 2 – TMY monthly values	10
Figure 3 – Typical foundation, pad and chimney.....	28
Figure 4 – Security Schema.....	34
Figure 5 – Monitorization System Schema	37
Figure 6 – Occupied area	39
Figure 7 – ITC Building	41
Figure 8 – CC Building	41
Figure 9 – PV structure Lay-out	42
Figure 10 – Views of the PV structure	42
Figure 11 – Krinner screw, reinforced concrete foundation and drive steel profile	43
Figure 12 – Typical sketch.....	43
Figure 13 – ITC foundation.....	44
Figure 14 – Control Center and Warehouse foundation.....	44



List of Tables

Table 1 - TMY monthly values.....	9
Table 2 – Model assumptions.....	10
Table 3 – Performance results.....	13
Table 4 – Generating System 2.3 MW. Main Characteristics	14
Table 5 – Generating System 1.2 MW. Main Characteristics	14
Table 6 – PV Module. Main Characteristics	15
Table 7 – 1164 kW Solar Inverter. Main Characteristics	15
Table 8 – 2.3MW Block. Medium voltage transformers. Main Characteristics	17
Table 9 – 1.2MW Block. Medium voltage transformers. Main Characteristics	17
Table 10 – 10kVA Auxiliary low voltage power transformers	17
Table 11 – 50kVA Auxiliary low voltage power transformers	18
Table 12 – CAPEX estimation breakdown.....	48
Table 13 – OPEX estimation breakdown	49
Table 14 – Key assumptions for financial analysis and forecasts.....	50
Table 15 – Power generation overview – (GWh).....	51
Table 16 – INVESTMENT COST.....	52
Table 17 – Overall project financing scenario	53
Table 18 –Summary of loan conditions	53
Table 19 – OPEX cost – (US\$).....	54
Table 20 – Revenue overview	55
Table 21 – I/S projections overview	55
Table 22 – Overview of cash flow projections (USD)	56
Table 23 – I/S DSCR projections	56
Table 24 – Impact of CAPEX variation	58
Table 25 – Impact of D/E ratio variation.....	58
Table 26 – Impact of equity remuneration.....	58
Table 27 – Drawings.....	60
Table 28 – Annexes.....	61



1 EXECUTIVE SUMMARY

The present document describes the result of the feasibility study prepared for a Solar PV 16.29MW power plant located in the municipality of Masrik. These works are part of the activities carried out by Af Aries Energía for the Armenia Renewable Resources and Energy Efficiency Fund (henceforth the Client) within the contract "Feasibility Study and Transaction Advisory Services for Preparation of Utility-Scale Power Project".

The land plot used for the study was selected during the previous stages of the project based on meteorological, topographical, environmental and other characteristics, as well as shape, available area and accesses, in order to optimize the development of the project.

Apart from a revision of the available sources of information about the site and several site visits, a topographical desktop study has been carried out to confirm the suitability of the land from this perspective.

During the previous stages of the project, a preliminary assessment of the technology was carried out considering fixed versus single axis tracking technology. The result showed that there was a minor improvement in the cost of electricity for the one axis tracking structure. In any case it was agreed with the Client to consider fixed structures for the design because the improvement in the electricity cost for the tracking technology was very low and it had other disadvantages like higher risk and higher area needed.

Af Aries Energía has rendered a plant design, including its grid connection infrastructure, adjusted to the specific characteristics of the Site, in order to assess the feasibility of a PV plant in the selected Site.

The proposed design consists of 6 units with nominal output power of 2.3MW plus 2 units of 1,2MW, each one formed by several parallel and series associations of photovoltaic modules, which in turn are mounted on fixed structures with horizontal PV module assembly.

Using this design, the Typical Meteorological Year of the area provided by the Client and the characteristics of the surrounding obstacles, the plant performance and production has been calculated showing a capacity factor of 22,2% which is a quite good result for this kind of technology.

An estimation of the cost has also been included, taking into account the proposed design and the international and local market prices and tendencies.

Considering the estimated costs and production, as well as the financial structure and conditions expected for the project, a financial assessment has been rendered with a result of US\$ cents 9,76 per kWh ("flat tariff type").

The result shows that the project is feasible from the financial point of view. It is suggested to prepare a sound legal framework to help the developers to reduce the profit required which may have a strong impact.

On top of this, it is paramount to design a proper bidding process to achieve a high level of competition which could optimize the estimated investment costs and reduce the tariff.



2 CODES AND STANDARDS

PV Farm Project will be designed according to the technical and legal regulations currently in force in Armenia.

It must comply with applicable Armenian laws and regulations, national, regional or local level, and the regulations or directives of the International Electrotechnical Commission apply force at the time of order placement

- IEC 60904-1: Photovoltaic devices
- IEC 61683: Photovoltaic systems - Power conditioners - Procedure for measuring efficiency
- IEC 61727: Photovoltaic (PV) systems - Characteristics of the utility interface
- IEC 61730: Photovoltaic (PV) module safety qualification
- IEC 62093: Balance-of-system components for photovoltaic systems - Design qualification natural environments
- IEC 62124: Photovoltaic (PV) stand alone systems - Design verification
- IEC 61557-1: Electrical safety in low voltage distribution systems up to 1000 V a.c. and 1500 V d.c
- IEC 61558: Specification for safety of power transformers, power supply units and similar apparatus
- IEC 61173: Over-voltage protection for photovoltaic (PV) power generating systems
- IEC 61194: Characteristic parameters of stand-alone photovoltaic (PV) systems
- IEC 61724: Photovoltaic system performance monitoring - Guidelines for measurement, data exchange and analysis
- IEC 62446: Grid connected photovoltaic systems - Minimum requirements for system documentation, commissioning tests and inspection
- ISO 9355-1: Ergonomic requirements for the design of displays and control actuators

Applicable editions of these standards will be the last published, including corrections, at the time of order placement

In case of conflict between standards, the most stringent requirements will prevail.



3 SITE LOCATION

The preliminary site analysis results indicate that the selected area for the photovoltaic plant is suitable: good solar resource, good communication infrastructures, adequate orientation, without environmental constraints and free from trees or any kind of building which could produce shadows, decreasing the performance ratio of the photovoltaic modules.

The site data are:

- Location: Vardenis, Gegharkunik Marz (Armenia)
- Geographical coordinates and altitude:
 - Latitude: 40° 9.918' N
 - Longitude: 45° 44.915' E
 - Altitude: 2000 m above sea level

Figure 1 – Site location (Source: Google Earth)

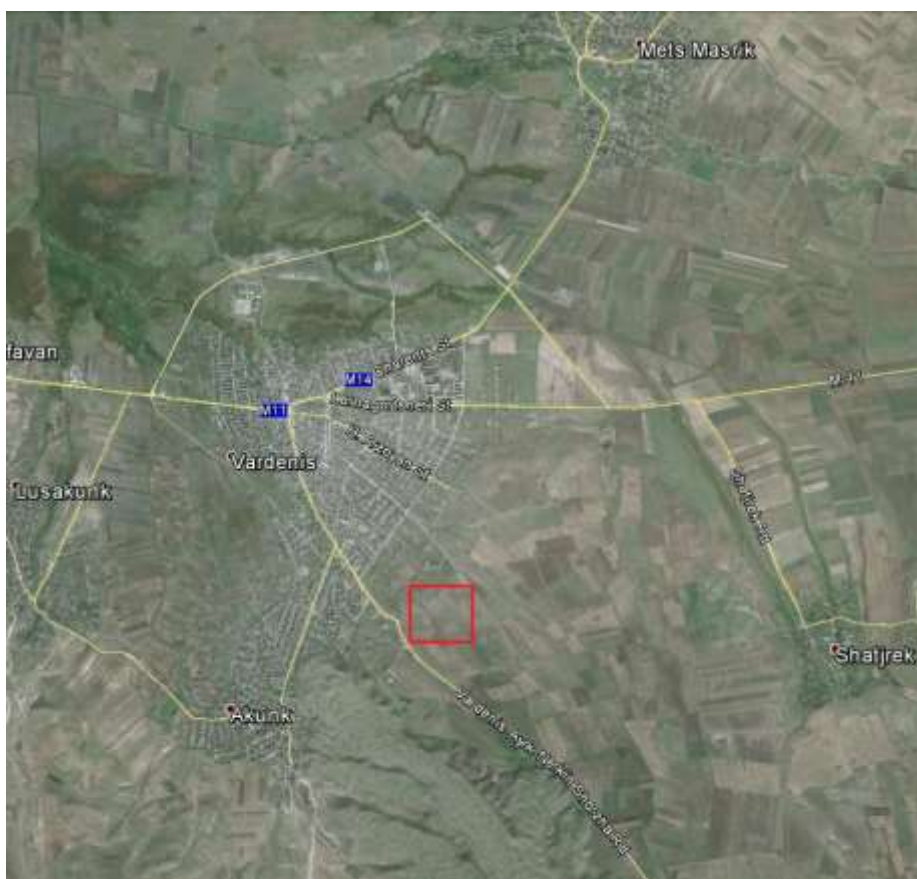

This analysis is described in the following sections.



4 GENERAL DESCRIPTION

The PV plant is divided in two land plots which are one next to each other so it can be considered as one final plot for the plant. The net power capacity of PV plant is 16.29MW (AC) with a peak power installed of 19.40MWp and ratio DC/AC 1.19.

The photovoltaic system consists of 6 units with nominal output power of 2.3MW (General Block-2.3MW) and 2 units with nominal output power of 1.2 MW (General Block-1.2MW). These production units (hereafter ITC "Inverter Transformer Center") are formed by several parallel and series associations of photovoltaic modules, which in turn are mounted on a fixed structure with horizontal PV module assembly.

- ITC contains following MV switchgear:
 - 1 Incoming switchgear
 - 1 Outgoing switchgear
 - 1 Protection switchgear

As stated in document PEF2827-005-Preliminary Feasibility Study, the differences between fixed structures and tracking systems are the following:

- Fixed structure requires less area per MW.
- The cost of the structure increases from fixed structures to tracking systems.
- The global performance of PV plants with solar tracking systems is greater than PV plants with fixed structures.
- The installation of fixed structure is easier than tracking systems.
- The construction period of a plant with tracking systems is considerably larger than fixed structures.
- The LCOE (Levelized Cost Of Electricity) is lower in PV plants designed with solar tracker system than in PV plants designed with fixed structure.
- O&M in PV plants with fixed structure is easier than PV plants with tracker systems.
- The availability of a fixed structure plant is higher than PV plants with tracker systems.
- Risks of damage of a PV plant are higher with tracking structure.
- Fixed structures are much more resistant to wind than tracking structures.
- Tracking structures increase in auxiliary electricity consumption.

This feasibility study has been developed with fixed structure, but the final design of the PV plant can be made with any of the types at bidder's choice to find their optimum configuration at any case.

Fixed structures will be formed 3 rows of 19 PV panels (57 PV panels per structure) and it will be south oriented.

- General Block – 2.3MW

There will be connected 152 PV fixed structures of 3 rows with 19 PV panels per 2.3MW ITC (8664 PV panels).

Each 2.3MW ITC has two 1164kW inverters. Solar inverters are used to convert the direct current generated by PV modules into alternating current of low voltage. A double secondary



power transformer (one secondary winding for each inverter) will raise it to medium voltage under optimal conditions of voltage and frequency for grid connection.

- General Block – 1.2MW

There will be connected 76 PV fixed structures of 3 rows with 19 PV panels per 1.2MW ITC (4332 PV panels).

The 1.2MW ITC has one 1164kW inverter. Solar inverters are used to convert the direct current generated by PV modules into alternating current of low voltage. A single secondary power transformer will raise it to medium voltage under optimal conditions of voltage and frequency for grid connection.

Each ITC will be equipped with an auxiliary power transformer which will supply energy to necessary auxiliary services for proper operating of PV plant (inverter power supply, lighting, monitoring, power suppliers, etc...).

The interconnection of the 8 production units that composed the PV Plant will be by 2 circuits of 3 ITCs (2.3MW+2.3MW+1.2MW) and 1 circuit of 2 ITCs (2.3MW+2.3MW) each through medium voltage cables (10kV). These aluminum medium voltage cables will be preferably installed under duct through several trenches converge in the Connection Center (CC). The design criteria to do the cable calculations will be that the maximum drop voltage in LV are 2% in DC side and 1% AC side.

In the CC will be interconnected the internal medium voltage power lines (10kV) with 110kV PV electrical substation with capacity of 2x25MVA which will be connected to the energy system at the nearest tension towers of 110kV "Sotk" and "Parvana" overhead lines by constructing about 0.3km overhead branch lines (T-off lines).

- Connection Center contains following MV switchgears:
 - 3 Line switchgears, that correspond with the 3 connection circuits
 - 1 PV production measurement/coupling switchgear
 - 2 Evacuation switchgear
 - 1 Auxiliary Services Protection Switchgear

The CC will be equipped with certified and homologated measurement system connected to the MV switchgears to get a measurement of the net energy.

From the CC an auxiliary power transformer will supply the necessary energy to devices (Aux. Services, lighting, power suppliers, etc.) of the Control Center used to control the operation of PV plant and Warehouse used to store maintenance elements. The consumption of the auxiliary services of the photovoltaic plant will be upstream of the general PV production to discriminate incoming and outgoing power.

Due to the PV plant location, the design of main equipment shall take into account the altitude of the site about 2000m above sea level.

Due to the PV plant location, the design of main equipment shall take into account the altitude of the site above sea level and it is foreseen that snow precipitations occur. The effect of snow is complicated and depends on several climate factors such as daily snowfall, snow depth, wind, temperature, temperature cycles, and irradiance. So the climate plays a role in system design (tilt and module height), mounting structure specifications and operations and maintenance

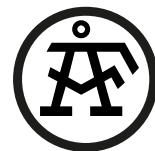

plans (snow cleaning). The snow cleaning has already been taken into account in the operation and maintenance assumptions.

Generally fixed tilted systems are employed on sites with high wind or snow loads. However, some tracker suppliers have developed new products adapted to those kinds of climates. High snow loads increase stress on structural members and components, so tracking systems require additional steel and other materials, driving up costs.

5 SOLAR RESOURCE ANALYSIS

In order to estimate the expected electric output of a PV plant, a Typical Meteorological Year (TMY) is needed. The objective of a TMY is to represent the long-term average meteorological conditions at a site. The TMY shall be based on as many years as possible (ideally up to 30 years of site-specific observations and measurements). This TMY, based on long term historical data, provides the expected behavior in the long term (20 years or more), which is approximately the expected lifetime of a PV plant.

Thus, the TMY shall meet the following requirements:

- Representative of the natural years in the location
- Main meteorological parameters related to natural years
- Extrapolable to future years

The objective of the TMY is not reproducing typical meteorological parameters at a particular time in the future, but reproducing the trends of the main meteorological parameters over the short term (seasonal trends) and the long term (annual trends), respectively, at a given location.

Often, getting this TMY from ground measured data is not possible, since it depends on the weather station network available in a country or region. However, satellite data can provide the long-term data series, while ground-measurements provide more accurate data with highest time-resolution.

Most of the inherent modeling uncertainty is tied up to the choice of the weather data file, thus the importance of the consistency in the meteorological data.

The solar radiation is a meteorological variable measured only in few stations and during short and, on most occasions, discontinuous periods of time. Solar radiation estimation from satellite images is currently the most suitable approach. It supplies the best information on the spatial distribution of the solar radiation and it is a methodology clearly accepted by the scientific community and with a high degree of maturity.

AF Aries Energía has received from Client, TMY based on satellite data generated by an external company for each site for the use in the preliminary energy yield assessment. The following table shows TMY monthly values for this site:

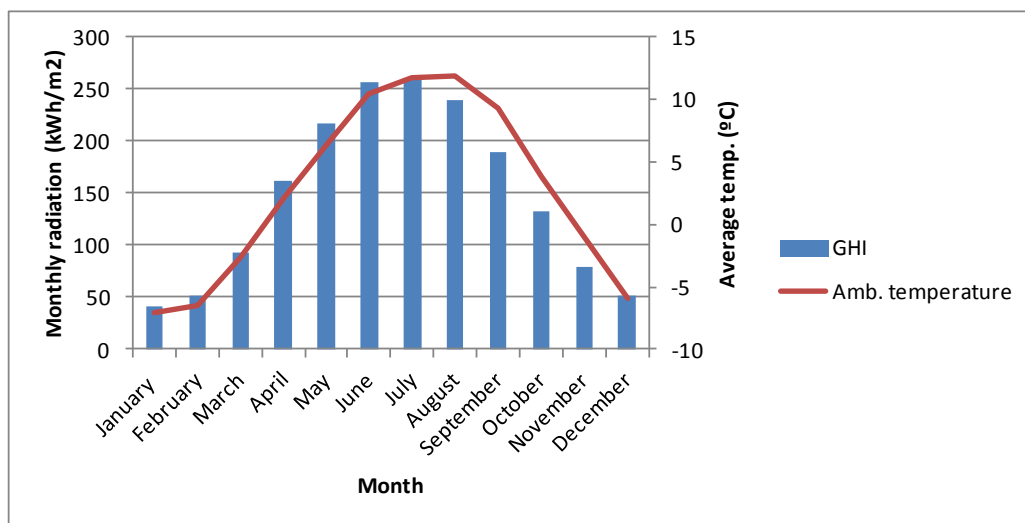

Table 1 - TMY monthly values

	GHI (kWh/m²)	TEMP. (°C)
January	40.5	-7.04
February	52.0	-6.55
March	91.9	-2.64
April	161.1	2.06
May	216.3	6.46
June	256.5	10.50
July	260.0	11.81
August	238.5	11.85
September	189.7	9.29
October	132.9	3.86
November	79.2	-1.10
December	51.6	-5.98
YEAR	1770.1	2.76



Figure 2 – TMY monthly values



6 ENERGY YIELD ASSESSMENT

6.1 Model inputs and assumptions

To undertake the energy yield assessment, ARIES has used PVSyst v6.43. PVSyst is a PV simulation tool developed initially at the University of Geneva, Switzerland. PVSyst is one of the most complex PV performance and financial model design tools in the industry. It was one of the first commercially available PV design packages; the newest versions are capable of precise output design of utility scale projects.

An annual performance analysis has been developed, to outline the impact of the most significant parameters which would affect the performance of the plant and the energy yield.

The following table outlines the main assumptions used by AF Aries Energia.

Table 2 – Model assumptions

ITEM	VALUE	COMMENT
Orientation	South	Azimuth 0°
Mounting system	Fix structure	
Ground albedo	0.2	Ground reflectance.
Module	JKM320PP-72	Jinko Solar 320 Wp
# modules	60648	
Inverter	Ingecon Sun 1165TL B420	Ingeteam 1164 kW at 30°C
# inverters	14	
Far shading/horizon losses	0.7%	Based on horizon profile from surrounding mountains in N and W side.
Shading losses	2.1%	Mutual shading between rows based on structure



ITEM	VALUE	COMMENT
		design: 28° tilt and 7 m pitch between rows.
IAM losses	2.3%	PVsyst calculation for the Project site location.
Soiling losses	2.0%	Assumed.
Irradiance losses	0.3%	Low irradiance losses.
Temperature losses	2.0%	PVsyst calculation based on the meteorological data for the chosen location and the selected PV module technology.
Module quality losses	-0.7% (gain)	0/+5W positive tolerance of modules.
LID losses	1.0%	The light-induced degradation (LID) has been assumed based on available test data for polycrystalline modules currently on the market.
Mismatching losses	1.0%	Losses due to modules different electrical parameters.
Electrical DC losses	1.5% at STC	1.1% of energy loss.
Inverter losses	1.50%	PVsyst calculation based on the module's and inverter's characteristics, sizing of the inverters, and the environmental conditions.
Inverter clipping losses	2.80%	Overpower losses.
Auxiliary losses	0.50%	Energy loss.
Electrical AC losses	0.5% at STC	0.3% of energy loss.
Transformer LV/MV and MV/HV losses	2.0%	Assumed: iron losses and load losses.
Plant availability	99%	This value is assumed based on project experience.

The energy value includes also evacuation line losses up to interconnection point.

6.2 Glossary of terms

GlobHor: Total irradiance on a horizontal surface, as read from the meteorological data file.

TAmb: Ambient temperature, as read from the meteorological data file.

GlobInc: Irradiance corrected for the array orientation.

GlobEff: Irradiance corrected for the array orientation, shading objects, and incidence angle (reflection).

EArray: DC energy at the inverter input.



EOutInv: Energy at the inverter output.

EffArrR: Efficiency of the array (EArray / rough area of system).

EffSysR: Efficiency of the system (EOutInv / rough area of system).

Horizontal global irradiation: Amount of sun at a horizontal surface at the array's location.

Global incident in coll. Plane: Correction to irradiation to account for additional light reaching the modules due to module orientation (tilt and azimuth, or tracking with backtracking if applicable).

Horizon shading Factor on global: Correction to irradiation to account for less light reaching the array due to horizon objects (i.e. mountains).

Near Shading Factor on global: Correction to irradiation to account for less light reaching the modules due to shading by nearby objects (e.g. other rows of modules).

IAM factor on global: Correction to irradiation to account for less light reaching the modules due to incidence angle effects.

Effective irradiance on collectors: Total irradiation reaching the cells, accounting for all irradiation losses and enhancements.

PV conversion: Module efficiency at standard test conditions (STC). STC is defined as irradiance levels of 1000 W/m², module temperatures of 25°C, and AM 1.5 spectral distributions. The efficiency shown here reflects the output of the PVSYST module model rather than the specification sheet quoted value.

PV loss due to irradiance level: Losses due to (typically) reduced module efficiency at light levels below 1000 W/m². This quantity represents the annual average impact of this irradiance dependent effect.

PV loss due to temperature: Losses due to reduced module efficiency at temperatures above 25°C. For operation in cold environments, this may be a gain relative to STC.

Array Soiling loss: Annual losses due to snow and dirt buildup preventing some light from reaching the active layers of the modules.

Module quality loss: A directly applied "across-the-board" loss used to account for lot average power output falling short of nameplate rating. BEW often applies other "across-the-board" losses here such as transformer core losses.

Module array mismatch loss: Losses due to the combination of series current and parallel voltage mismatch can be estimated analytically via PVSYST as long as the production tolerance, nature of the distribution, and number of series and parallel strings is known.

Spectral correction for amorphous: A correction to account for amorphous modules different absorption characteristics from those of crystalline silicon modules.

Ohmic wiring loss: Given a value for ohmic loss at STC, PVSYST calculates the annual loss, correcting for deviations from STC.

Array virtual energy at MPP: DC energy at the maximum power point (MPP) after all the losses listed above have been taken into account.

Inverter loss during operation (efficiency): Inverter losses due to its efficiency curve.



Inverter Loss over nominal inv. Power: Inverter losses due to AC power output limitation.

Inverter Loss due to power threshold: Inverter losses due to array output below the inverter lower limit. Inverters typically fall back to a low-power standby state at night when the input power falls below this level. If this level is too high, a significant amount of available power may not be converted. This lost opportunity is counted as a loss due to power threshold.

Inverter Loss over nominal inv. Voltage: Inverter losses due to array voltage higher than inverter upper voltage limit for maximum power tracking.

Inverter Loss due to voltage threshold: Inverter losses due to array voltage below the inverter lower limit. To transition from nighttime standby to daytime operation, the inverter turns on when the (open circuit) array voltage exceeds a threshold. If this level is too high, a significant amount of energy may not be converted. This lost opportunity is counted as a loss due to voltage threshold.

Available Energy at Inverter Output: Energy at inverter output after all losses listed above are taken into account.

6.3 Performance results

AF Aries Energía has performed an analysis of the impact of the most significant parameters which would affect the performance of the plant and the energy generation.

The results of the performance analysis are as follows:

Table 3 – Performance results

ITEM	VALUE
Energy generated (MWh/year)*	31718
Energy generated (MWh/year)**	31401
Specific energy (kWh/kWp/year)*	1634
Specific energy (kWh/kWp/year)**	1618
Performance Ratio	82.6%

* PVSYST simulation is performed taking into account 100% availability.

** Energy values are also provided assuming 99% plant availability.

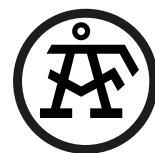

7 INSTALLATION DESCRIPTION

7.1 Generating System

The generating system consists of a group of PV modules connected in series and in parallel with each other to achieve an optimal level of output voltage and current ranges compatible with the input of inverter model selected.

The photovoltaic system consists of:

- 6 blocks of 2.3MW
- 2 blocks of 1.2MW.

Each 2.3MW block has 456 (14 combiner boxes x 30 parallel series per combiner box plus 2 combiner boxes x 18 parallel series) series in parallel. Each series is composed by 19 PV panels connected in series.

Table 4 – Generating System 2.3 MW. Main Characteristics

Description	Value	Units
Number of PV modules in series	19	panels
Number of Series per ITC(General Block) of 2.3 MW	456	series
Number of Modules per ITC(General Block) of 2.3 MW	8664	modules
Number of ITC(General Block) in PV Plant	5	ITC´s

The 1.2MW block has 228 (7combiner boxes x 30 parallel series per combiner box plus 1 combiner boxes x 18 parallel series) series in parallel. Each serie is composed by 19 PV panels connected in series.

Table 5 – Generating System 1.2 MW. Main Characteristics

Description	Value	Units
Number of PV modules in series	19	panels
Number of Series per ITC(General Block) of 1.2 MW	228	series
Number of Modules per ITC(General Block) of 1.2 MW	4332	modules
Number of ITC(General Block) in PV Plant	1	ITC´s

The parallel connection of the PV modules series will take place in direct current combiner boxes distributed by the solar field. In this combiner box, will be installed protection (fuses and surge arrester) and switch-disconnector of series that will allow maintenance and switching operations.



7.2 Modules

The installation of 16.29MW (19.40MWp) consists of 60648 modules of 320Wp power with the following characteristics:

Table 6 – PV Module. Main Characteristics

Description	Value	Units
Model	JKM320P	
Technology	Polycrystalline	
Max-Power	320	Pm(Wp)
Max-Power Voltage	37.4	Vm(V)
Max-Power Current	8.56	Im(A)
Open-Circuit Voltage	46.4	Voc(V)
Short-Circuit Current	9.05	Isc(A)
Coef T ^a Voc	-0.31	%/°C
Coef T ^a Isc	0.06	%/°C
Maximum System Voltage	DC1000	V
Length	1.956	m
Width	0.992	m
High	0.04	m
Weight	26.5	kg

7.3 Inverters

Each inverter will receive the DC power generated by its subsystems and transform it into AC power, to evacuate it to the grid. To generate the 16.29MW (19.40MWp) there will be a total of 14 inverters 1164kW of power in the PV plant.

This inverter selection is done by the possibility that receive set-points signals to compensate reactive power, voltage ride-through... etc. The inverter will comply with the applicable standards.

Table 7 – 1164 kW Solar Inverter. Main Characteristics

Description	Value	Units
Model	INGECON SUN 1165TL B420 Outdoor	
Max. DC power	1513.2	kW
Max. DC voltage	1050	Vdc
MPP voltage range	610 - 820	Vdc
Max. DC current	2000	A



Description	Value	Units
Max. AC power at 35°C	1163.9	kVA
Max. AC power at 50°C	1071	kVA
AC output voltage	420	Vac
AC grid frequency	50-60	Hz
Dimensions	2820/2200/920	mm
Weight	1920	kg
Protection rating	IP 54	
Power factor (cos φ)	± 1 adjustable	
Operating temperature range	-20 to +65	° C
CEC efficiency	98.70	%
Max. Altitude above sea level	3000	m

7.4 Combiner boxes or junction boxes

The combiner boxes or junction boxes (JB) are used to group the number of strings to one output and to protect the strings with fuses. The JB will be prepared up to 30 strings.

The JB will be equipped with different devices:

- Fuses: to protect the strings against the electrical faults
- Switch-disconnector to do an electrical separation and disconnect all the strings that the JB joins.
- Overvoltage devices (electrical discharger) to protect it against overvoltage faults.
- Ground terminal and ground connection: to protect the device against electrical risks.

7.5 Generation Medium voltage transformers

In PV plant will be installed 4 medium voltage transformers of 2.3MVA and 1 medium voltage transformer of 1.2MVA, one by each ITC.

The transformers will be employed to step up the low voltage output from inverters to the internal medium voltage of the plant that is 10kV. The 2.3MW ITC blocks transformers will have double secondary windings to optimize the interconnection with the two inverters and the 1.2MW ITC block will have only a single winding to connect its inverter. The transformers will be with very low losses (1%).

There will be placed in prefabricated galvanized steel buildings (container-type) with inverters and auxiliary power transformers.

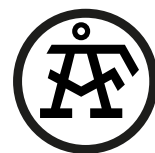

Table 8 – 2.3MW Block. Medium voltage transformers. Main Characteristics

Description	Value	Units
Transformer Rated Power	2330	kVA
Phases	3 Phase	
Nominal Frequency	50	Hz
High Voltage	10000	V
Low Voltage	420	V

Table 9 – 1.2MW Block. Medium voltage transformers. Main Characteristics

Description	Value	Units
Transformer Rated Power	1200	kVA
Phases	3 Phase	
Nominal Frequency	50	Hz
High Voltage	10000	V
Low Voltage	420	V

NOTE: Due to the PV plant location, the design of generation medium voltage transformers shall take into account the altitude of the site above sea level.

7.6 Auxiliary Medium voltage transformers

In PV plant will be installed 6 low voltage power transformers (10kVA) for the auxiliary services of ITCs and 1 medium voltage power transformer (50kVA) for the auxiliary services of Control Center and Warehouse.

The auxiliary low voltage power transformers will be located inside of ITCs and it will be employed to step down the output voltage of inverters (420V) to supply the necessary energy for the auxiliary services of each ITC.

Table 10 – 10kVA Auxiliary low voltage power transformers

Description	Value	Units
Transformer Rated Power	10	kVA
Phases	3 Phase	
Nominal Frequency	50	Hz
High Voltage	420	V
Low Voltage	400	V

The auxiliary medium voltage power transformer will be located inside of Connection Center and it will be employed to step down medium voltage of the grid connection (10kV) to low voltage (400V) of auxiliary services electrical consumptions of Control Center and Warehouse.



Table 11 – 50kVA Auxiliary low voltage power transformers

Description	Value	Units
Transformer Rated Power	50	kVA
Phases	3 Phase	
Nominal Frequency	50	Hz
High Voltage	10000	V
Low Voltage	400	V

NOTE: Due to the PV plant location, the design of auxiliary power transformers shall take into account the altitude of the site above sea level.

7.7 Low voltage Cable

7.7.1 DC Cable 1

This cable will be employed to connect the module with combiner boxes or junction boxes.

7.7.1.1 Constructive characteristics

Cable: Cable for PV system, single core insulated, with additional coating, type P-Sun 2.0.

Isolated conductor: Isolated conductor without cover.

Insulation types:

- Thermostable: XLPE.
- Acronym:
 - R: insulation XLPE (cross-linked polyethylene).

The specified insulation has different temperatures:

(Max.Operating Temp – Max.Overload Temp – Max.Short-circuit Temp (max 5 s.))

- XLPE (90 - 120 – 250)

Each pole shall be identified during the laying operation using different colors of a PVC tape around the cable, both in the beginning and end of lying, as in the joints.

All cables shall be marked on the outer cover, indicating every meter the length of each roll referred to the beginning of the coil wire.

All cable shall have printed each meter with the data below, in a legible and indelible way. It must be printed on the outer cover: manufacture identification, cable description, year manufacture identification (2 last digits), certification mark, number of conductors and their section, insulation voltage, and length mark.

7.7.1.2 Particular characteristics.

- Type: P-Sun 2.0
- Conductor: stranded electrolytic copper, tinned, and compressed.
- Flexibility: class 5. Flexible to handle easily.
- Rated voltage and the basic isolation level (BIL) will prepare for 0.6/1 kV.

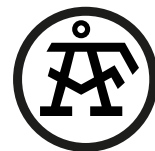

- Insulation: XLPE.
- Sheath: EVA 120°C (Ethylene-Vinylacetat-Copolyme).

Behavior in case of fire

- Halogen-free.
- Low smoke emission.
- Corrosivity according to DIN EN 502641.

7.7.2 DC Cable 2

This cable will be employed to connect combiner boxes or junction boxes with PV inverter.

7.7.2.1 Constructive characteristics

Cable: Single-core isolated conductor with additional sheath.

Isolated conductor: Isolated conductor without cover.

Types of insulation: Thermostable: XLPE.

Depending on the type of insulation, the differences are:

(Max. Service Temp – Max overload Temp. – Max. Shortcircuit Temp. (5 s. Max.)

- XLPE (90 - 105 – 250)

In single core cables for each phase is identified by a tape laying of PVC in different colors around the cable, both the beginning and end of lying as in the joints and manholes by encoding suitable.

All cables have a marking on the outer cover, which indicates, meter by meter, the length of each pull cable mentioned at the beginning of the coil.

The coils are marked as indicated in the Supply Contract; the number identifying the coil will be appointed following an encoding that is defined later during the order placement.

All cable shall have printed each meter with the data below, in a legible and indelible way. It must be printed on the outer cover: manufacture identification, cable description, year manufacture identification (2 last digits), certification mark, number of conductors and their section, insulation voltage, and length mark.

7.7.2.2 Particular characteristics.

- Designation: Al XZ1.
- Conductor: Class B concentric compact aluminum.
- Flexibility: class 2.
- Isolation voltage: 0.6/1 kV.
- Insulation: XLPE.
- Screen: No.
- Cover: Special mix zero halogen type DMO1.

Characteristics against the fire:

- No flame propagation.

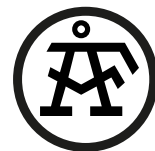

- Low smoke emission.

7.7.3 AC Cables

This cable will be employed to feed all the auxiliary services.

7.7.3.1 Constructive characteristics

Cable: Isolated conductor with additional sheath, both single-core and multi-core.

Isolated conductor: Isolated conductor without cover.

Types of insulation: Thermostable: XLPE.

Depending on the type of insulation, the differences are:

(Max. Service Temp – Max overload Temp. – Max. Shortcircuit Temp. (5 s. Max.)

- XLPE (90 - 105 – 250)

In single core cables for each phase is identified by a tape laying of PVC in different colors around the cable, both the beginning and end of lying as in the joints and manholes by encoding suitable for three-core cables.

All cables have a marking on the outer cover, which indicates, meter by meter, the length of each pull cable mentioned at the beginning of the coil.

The coils are marked as indicated in the Supply Contract; the number identifying the coil will be appointed following an encoding that is defined later during the order placement.

All cable shall have printed each meter with the data below, in a legible and indelible way. It must be printed on the outer cover: manufacture identification, cable description, year manufacture identification (2 last digits), certification mark, number of conductors and their section, insulation voltage, and length mark.

7.7.3.2 Particular characteristics.

- Designation: RV-K.
- Conductor: stranded electrolytic copper, tinned, and compressed
- Flexibility: class 5. Flexible to handle easily.
- Isolation voltage: 0.6/1 kV.
- Insulation: XLPE.
- Screen: No.
- Cover: Polyvinyl chloride (PVC), type DMV-18.

Characteristics against the fire:

- No flame propagation.
- Low smoke emission.

7.8 MV AC Cable

7.8.1 MV cables for PV Plant

- Conductor: Compact circular stranded compacted aluminum



- Conductor screen: Extruded semi-conducting compound bonded to the insulation and applied in the same operation as the insulation.
- Insulation: Extruded cross-linked polyethylene (XLPE) suitable for operation at a conductor temperature of 90°
- Insulation screen: Extruded semi-conducting compound applied in the same operation as the insulation. Cold strippable screens are supplied as standard but fully bonded screens may be provided if specified.
- Metallic screen: Copper tapes applied overlapped to provide an earth fault current path.
- Tape Separator
- Oversheath: Extruded black polyvinyl chloride (PVC) or Low Smoke Zero Halogen (LSOH) compound is supplied as standard. Alternative materials may be provided if specified e.g. medium density polyethylene (MDPE).

In single core cables for each phase is identified by a tape laying of PVC in different colors around the cable, both the beginning and end of lying as in the joints and manholes by encoding suitable for three-core cables.

All cables have a marking on the outer cover, which indicates, meter by meter, the length of each pull cable mentioned at the beginning of the coil.

The coils are marked as indicated in the Supply Contract; the number identifying the coil will be appointed following an encoding that is defined later during the order placement.

All cables will cover printed indelibly marked each meter at least the following information:

- Identification of the manufacturer.
- Name of the cable.
- Identification of the manufacturing year.
- Mark of the certification.
- Number and cross section of the cables.

7.9 Switchgears

There will be two different types of switchgears as specified:

7.9.1 ITC Switchgears

There will be these types of switchgears: transformer protection and incoming and outgoing switchgear. The main characteristics are:

- Model: SM6 (Schneider or similar).
- Load break switch: 3 positions (closed, opened and ground connected).
- Rated maximum voltage: 24 kV.
- Rated impulse BIL: 125 kV.
- Insulation (Ud) 50/60 Hz, 1 min (kV rms): 50
- Isolation (Ud) 50/60 Hz, 1 min (kV rms): 60
- Insulation Up 1.2/50 μ s (kV peak): 125
- Isolation Up 1.2/50 μ s (kV peak): 145

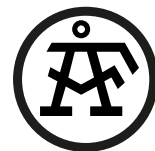

- Rated current: 630 A.
- Gas insulated: SF6
- Nominal frequency: 50 Hz

NOTE: Due to the PV plant location, the design of switchgears shall take into account the altitude of the site above sea level.

7.9.2 CC Switchgears

There will be these types of switchgears: transformer protection, measurement, incoming and outgoing switchgear. The main characteristics are:

- Model: SM6 (Schneider or similar).
- Load break switch: 3 positions (closed, opened and ground connected).
- Rated maximum voltage: 24 kV.
- Rated impulse BIL: 125 kV.
- Insulation (Ud) 50/60 Hz, 1 min (kV rms): 50
- Isolation (Ud) 50/60 Hz, 1 min (kV rms): 60
- Insulation Up 1.2/50 μ s (kV peak): 125
- Isolation Up 1.2/50 μ s (kV peak): 145
- Rated current: 1250 A.
- Gas insulated: SF6
- Nominal frequency: 50 Hz

NOTE: Due to the PV plant location, the design of switchgears shall take into account the altitude of the site about 1880m above sea level.

7.10 Grounding General Description

A grounding system should be installed in a manner that will limit the effect of ground potential gradients to such voltage and current levels that will not endanger the safety of people or equipment under normal and fault conditions. The system should also ensure continuity of service.

The system of ground electrodes will have the form of a grid of horizontally buried conductors, supplemented by a number of vertical ground rods connected to the grid. Horizontal (grid) conductors are most effective in reducing the danger of high step and touch voltages on the earth's surface

Rods penetrating the lower resistivity soil are far more effective in dissipating fault currents whenever a two-layer or multilayer soil will be encountered and the upper soil layer has higher resistivity than the lower layers.

7.10.1 Grounding Conductors

Grounding conductors shall be stranded soft drawn annealed copper material or equivalent.



7.10.2 Grounding Rods

Ground rods shall be Copperweld material or equivalent.

As a general conception grounding system shall be such that when connected to other on site grounding networks, the electrical resistance between networks shall be 0.5Ω or less.

7.11 Auxiliary Services

The general auxiliary services of the PV plant will be feed from auxiliary medium voltage power transformer located inside of Connection Center. This auxiliary transformer will step down medium voltage of the grid connection to low voltage and it will be interconnected with the auxiliary low voltage panel board which will supply the auxiliary services of Control Center and Warehouse.

The general auxiliary services will be the following:

- Lighting
- Sockets
- Air-conditioning system
- Fire protections
- Security system
- Operation and control system
- Warehouse electrical consumption

On the other hand, the ITCs will have electrical consumption which will be feed from an auxiliary low voltage power transformer located inside of each ITC and it will step down the output voltage of inverters to low voltage of following auxiliary services:

- Inverter power supply
- Cooling fans power supply
- Lighting
- Sockets
- Smoke detectors
- MV Switchgears power supply
- Thermal protections
- Monitoring and Control equipment

7.12 Essential Services

To ensure proper operation of PV plant it is necessary the power supply to part of auxiliary services (essential services) shown in section above in case of grid failure.

The essential services of Control Center and Warehouse will be fed by an Emergency Diesel Generator in case of grid failure which will provide necessary low voltage power supply at least to following services:

- Fire Protections
- Security system

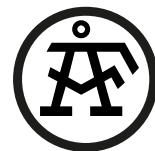

- Operation and control system
- Safe lighting
- Safe sockets

The independent fuel storage capacity shall be sufficient to maintain supplies to the PV plant for minimum 12 hours.

In addition, part of these essential services are considered critical services and it will be fed by an uninterruptible power supply (UPS) located in Electrical Room of Control Center in case of Emergency Diesel Generator failure. The essential services connected to UPS are:

- Operation and control system

The essential services of each Inverter Transformer Centers (ITC) will be fed by an uninterruptible power supply (UPS) located in each one and are the following:

- Inverter power supply
- Thermal protections
- Monitoring and Control equipment
- MV Switchgears power supply

NOTE: Annex "15.5 PEF2827-119-Masrik 2-BOM" shows an estimate bill of materials and main equipment required for this PV plant..

8 EVACUATION POWER LINE

8.1 General Summary

The existing high voltage lines (110 kV and above) in Armenia are designed and constructed according to GOST Standards.

For the purpose of optimization of investments, design and construction of the new lines will be done in accordance with the relevant IEC standards IEC 60826 / EN 50341. The application of these standards will not only result in a safe construction according latest state of art but allow a technical and economical optimization. The towers according to GOST are standard towers out of a modular system, which need more steel and a wider corridor space for the same application.

Experiences out of recent comparable projects in the region have shown an advantage of up to 20% reduced steel quantity for the "tailor-made" towers. All material and equipment can be manufactured in compliance with IEC/EN standards. Moreover guidelines of the SNIP/GOST/Armenian standards are to be fulfilled, for the highest voltages and the clearance distances to adjacent obstacles.

The information provided in this document is indicative only. The Investor and his contractor shall remain solely responsible for the design.

8.2 Technical Description

Construction of the 110 kV overhead lines from the substation of Masrik-2 PV plant will include:

8.2.1 Base scope

- 110 kV overhead line equipped with two circuits.

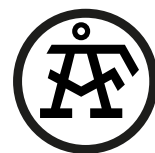

Conductors: Double circuit / 3 phases, each phase has one single 185 mm² ACSR (optional) conductor.

Ground wire: 1 ACS earth wire with internal greasing or OPGW.

Insulators: Composite insulators strings

- Towers: Steel lattice towers
Total length of the route: About 0.3 km
- Tee Connection to "Sotk" and "Parvana" 110 kV overhead transmission lines
- Altitude above sea level:
Masrik2 PV plant substation – 2023 m a.s.l
Sotkanchor tower – 2023 m a.s.l
Parvanaanchor tower – 2023 m a.s.l

8.3 Line route description

The final line route should be examined on site by the Contractor taking into account routing (provided by Consultant of the Project) attached to the specifications (in KMZ format). The attached route is proposed taking into account environmental considerations.

The final line route shall be examined by relevant expertise company and after that be submitted for approval to ENA.

8.4 Electrical Characteristics of 110 KV Transmission Lines

	Value	Unit
Nominal Voltage Un	110	kV
Highest System Voltage U _{max}	123	kV
Design Voltage U _m	123	kV
Frequency	50	Hz
Lightning impulse withstand voltage (BIL)	550	kV
System Configuration	Double Circuit	
Number of Conductor per phase	1	
Number of earthshield wire	1	
Rated continuous current capacity at ambient temperature of 15°C in still air	510	A
Rated power, at ambient temperature of 45°C in still air, conductor temperature 75°C	94	MVA
Short-circuit current and duration	31.5	kA/3s
Nominal Creepage Distance	31	mm/kV

8.5 Minimal clearance distance

8.5.1 Clearance distance between live part and the tower

The compliance with the minimal clearance distance as defined in the standards (EN 50341 and local) ensures the safety of persons, avoids arcing between conductors, between conductor and the tower, between conductors and obstacles beneath the line.



In order to meet these safety availability of operation goals, clearance distance to respect are:

Description	Conditions
Norms	EN 50341
Minimum clearance distance between live part and the tower in still air	minimum 1.04m

8.5.2 Clearance distances between live part and ground or other elements

The distances take into account a steady ground (non-moving).

Description	Conditions
Norms	EN 50341 and local
Above ground (general)	7m
Crossing of main roads	7 m
Crossing of other lines	highest minimum clearance distance between phase conductors of the two lines
Crossing of antenna and poles	3m
Vertical distance to houses roofs or buildings	7 m
Horizontal distance to houses roofs or buildings	3m
Horizontal distance to antenna	5 m

8.5.3 Clearance distance between phases

Description	Conditions
Norms	EN 50341 and local
Minimum clearance distance between phase conductors in still air,	minimum 1.35m
Minimum clearance distance between live part and the tower in max wind speed,	minimum 0.45m

8.6 Foundations

The Contractor shall determine the final location of each tower, survey the tower site, select the proper leg extensions necessary to provide tower height indicated in the plottings and construction schedules and select the type of foundation to be installed..

The key standards to be considered include:

D.T.U. NF P 06 001 (EUROCODE)	Bases for design of structures. Working loads for buildings.
EN 1991 Actions on structures	EN 1991 Actions on structures

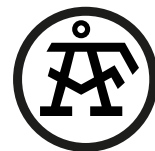

EN 1992 Design of concrete structures	EN 1992 Design of concrete structures
EN 1993 Design of steel structures	EN 1993 Design of steel structures
EN 1997 Geotechnical design	EN 1997 Geotechnical design
EN 50341-1 Overhead High voltage lines more than AC 45 KV	EN 50341-1 Overhead High voltage lines more than AC 45 KV
D.T.U. P 06 002: NV65, Rules for the definition of the actions of the snow and wind	D.T.U. P 06 002: NV65, Rules for the definition of the actions of the snow and wind
D.T.U. NF P 06 005: Notations - general symbols	D.T.U. NF P 06 005: Notations - general symbols
D.T.U. 13.1: Rules for the calculation of shallow foundations	D.T.U. 13.1: Rules for the calculation of shallow foundations
D.T.U. 13.2: Rules for the calculation of deep foundations	D.T.U. 13.2: Rules for the calculation of deep foundations
EN 1991 Actions on structures	EN 1991 Actions on structures

The Contractor is responsible for the consistency of the system of codes and standards selected as references, in particular when the codes and standards are from various origins. This consistency should be maintained during all stages of design and realization.

The calculation of the reinforced concrete of the foundations must be done in accordance with EN1990, EN1991, EN1992 and the Applicable National Standards.

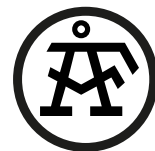
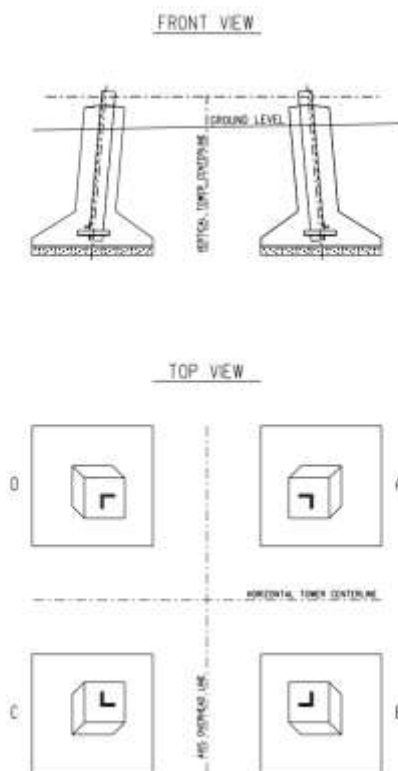

Figure 3 – Typical foundation, pad and chimney



8.6.1 Types and Choice of Foundations for Lattice Steel Towers

Types

Three types of foundations are assumed:

- reinforced concrete foundations on natural soil;
- reinforced concrete foundations on Soil improvement (including stone columns);
- pile-type foundations.

The choice of the type of Foundation depends mainly on the result of soil tests (complex engineering, geological, geomechanical surveys as per Armenian relevant applicable regulations, norms and standards) that the Contractor will perform at each tower location.

8.7 Towers

8.7.1 Standard Height of Towers

The standard height of towers shall be calculated with the maximum operating conductor temperature and the ground clearance for inhabited, accessible areas.



8.7.2 Minimum Ground - Live Conductor Clearances

These clearances are to be respected at maximum operating conductor temperature without wind. The maximum operating conductor temperature is given in part Conductors. The sag of the conductor shall be calculated for the basic span.

8.7.3 Minimum Tower - Live Conductor Clearances

These clearances are to be respected between live parts (conductor, jumper, arcing horn, ...) and the earthed tower.

Towers and their accessories, stubs, equipment shall be hot-dip galvanized, in accordance with the requirements of ENISO1461 standard and no retouching galvanizing shall be made.

8.7.4 Typical span

The design of the tower will take into account the following typical span:

Description	Conditions
Norms	EN 50341
Design span	280m
«wind» span	Shall be calculated by Contractor
«weight» span	Shall be calculated by Contractor

8.8 Tower Accessories

The towers will be provided with at least all the accessories mentioned in the hereunder:

- Anti climbing devices and ladder bolts
- Tower identification plates
- Three phase circuit and safety limit plates

8.9 Earthing

The design of earthing systems shall meet at least the following 3 requirements:

- a) to ensure mechanical strength and corrosion resistance by observing minimum dimensions;
- b) to withstand, from a thermal point of view, the highest fault current as determined by calculation;
- c) to ensure personal safety with regard to step and touch voltages appearing during an earth fault. Moreover damage to property and equipment shall be avoided.

Parameters relevant to earthing system dimensioning are thus:

- value and duration of fault current (given in 6.3.2 of EN 50341-1);
- characteristics for soil resistivity (given in H.2.1 of EN 50341-1 and local applicable standards).

Subclauses 6.2 to 6.4 of EN 50341-1 will be followed for the three design requirements of earthing systems.

8.9.1 Installation of earthing

The following principles are normally applicable:

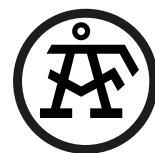

- loop around the foundations and the piles;
- measure at bottom of excavation of the beaten pile value and all of the piles after execution of the Foundation;
- Tetrapod towers: one driven pile vertically at bottom of the excavation by foot;
- concrete or metallic tubular supports: four (2 x 2) sunken vertically stacked piles;
- installation of earthing of towers near substations or underground pipes/utilities complies with the indications of the particular specification or specific plans.

8.10 Technical characteristics of the phase conductors

The phase conductor to be supplied shall be single of aluminum conductor steel reinforced (ACSR) 185/30 according to EN 50182.

The following standards will be applied:

- for complete conductor EN 50182
- for aluminium wires IEC(EN) 60889
- for steel wires IEC(EN) 60888
- for grease EN 50326
- for conductor creep IEC 61395

Main characteristics of the ACSR conductor are listed in the table below, according with EN 50182.

Conductor	185/30 (ACSR 185/30)
Nominal Al area (mm ²)	183.78
Nominal steel area (mm ²)	29.85
Actual area (mm ²)	213.6
Overall Ø (mm)	19.0
Weight (kg/km)	744
DC resistance (Ω/km at 20 °C)	0.157
Calculated Current-carrying capacity (A) <ul style="list-style-type: none">• Wind velocity 0.6m/s• Ambient temperature 35°C• Conductor temperature 80°C	535



8.11 Insulator Characteristics

Insulators sets shall consist of composite insulators units

Four types of string can be used, i.e.:

- single suspension sets;
- double suspension sets;
- single tension sets;
- double tension sets comprising two strings in parallel fixed on the cross-arm.

For safety reasons, the towers at each side of the following obstacle shall have double insulator sets:

- crossings of main roads;
- crossings of waterways;
- crossings of rail wails;
- crossings of any buildings;
- crossings of areas gathering crowds (markets, etc).

The electrical and mechanical specifications of the insulators are:

Description	Conditions
Standards	IEC 60815, 61109, 62217, 61446
Maximum Voltage (kV)	123kVpp
Pollution category	31 mm/Kv
Specific creepage distance	
Dielectric	Silicone (HTV)
industrial frequency withstand voltage (wet)	$\geq 275\text{kV}$
lightning impulse withstand voltage (dry)	$\geq 650\text{kV}$
Minimum creepage distance (mm)	$L_{fi} = L_{fp} \times U_m \times kD$ With : kD is a factor that depends on the insulator diameter; - kD = 1 for $D_m < 300 \text{ mm}$ - kD = 1.1 for $300 \leq D_m \leq 500 \text{ mm}$ - kD = 1.2 for $D_m > 500 \text{ mm}$
Safety factor for calculating the minimum tension of mechanical failure of the suspension and tension chains. To be demonstrated by the Contractor with calculation note	3
SML (suspension string)	70
SML (tension string)	At least 70
Disruptive length D_e IEC 60071-2	2100mm (peak-structure) 1900mm (conductor-structure)
Guard pieces	according to IEC 61284



8.12 Fitting Types

8.12.1 General information

This parts are designed in order to offer as extensive contact area as possible between two successive parts, this is done to reduce the electric resistance of equipment to short-circuit current flow. The single contacts are therefore to be prohibited unless otherwise stated in the preliminary design and particular specification documents. The material is adapted to the usual assembly and maintenance methods.

The following types of fittings shall be provided:

Suspension Equipment for Single Conductors

This equipment includes all fittings for connecting the conductor to the insulator string and for attaching the string to the cross arm or supporting structure.

All suspension equipment must be designed to hold conductors or shield wires with armour-rods.

Tension Equipment for Phase Conductors

This equipment includes all fittings and extension for connecting the conductor to the insulator string and for attaching the string to the cross arm or supporting structure, for forming the necessary jumpers and for attaching the conductors at substation terminal gantry.

Suspension Equipment for Shield wire

Including all fittings for connecting the shield wire to the supporting structures.

Tension Equipment for Shield wire

Including the fittings for connecting the shield wire to the supporting structure, conforming the necessary jumpers and for attaching the shield wire at substation gantry.

Tension Joints

For jointing the various lengths of conductors and shield wires. Joints are of the "compression" type.

Repair Sleeves

To be used in case of slight damage to the outer strands of conductors.

Vibration Dampers

To be provided for conductors and shield wire, according to a study to be realised by the Contractor.

Aircraft Warning Devices

Preformed Armour-rods

Armour-rods shall be used for phase conductors and shield wire at every suspension support. Armour rods shall be of preformed type.



9 SURVEILLANCE SYSTEM

The first security system will be a perimeter fence though its description is developed later in the civil works section. This surveillance system of the plant will be based on a video detection system

This system is continuously monitoring and processing video images in order to detect intrusions of people, vehicles and objects, and performing intruders tracking when a forbidden intrusion is detected.

When a non-allowed intrusion is detected, recording function is activated and alarms are generated and sent to the security office or Control Center.

This system is composed by fixed cameras, mobile cameras and automatic software for real time processing and analyzing images which detect models to determine when an intrusion is happening, avoiding false alarms and without permanent human participation.

This software permits several types of detection:

- One based on detection of object moving into a forbidden zone, or moving in a forbidden direction.
- Virtual line trespassed: the software allows defining several virtual lines per scene. If one of these lines is trespassed in a forbidden direction an alarm is activated.
- Object removal alarm: if an object is removed from its assigned place an alarm is activated.
- Unauthorized vehicles stop in a controlled zone
- Abandoned object: if an object is kept into an unauthorized zone for more than a predetermined period of time an alarm is triggered.

The role of mobile cameras is to track intruder movements when an alarm has been triggered and it is moving out of fixed camera scope.

The installation is scalable and allows future expansions if needed.

To implement the surveillance system, the following devices will be installed:

- Fixed cameras enabling video analysis and movement detection capabilities.
- Metallic posts installed on cement foundation where cameras are installed, with anti-sabotage system.
- Mobile camera to perform intruder movements tracking
- Infrared illumination focuses
- Surprising illumination and horns to be activated from the alarm center.
- Central surveillance monitoring center with operators HMI
- High quality recording system
- UPS with 2 hours capacity.
- Racks hosting electronic equipment in Control Center
- Auxiliary devices to protect the system against adverse meteorological conditions or power deviation.
- Data loggers



- Analyzers for image processing

Fixed cameras are to be installed every 50m, following the schema shown below:

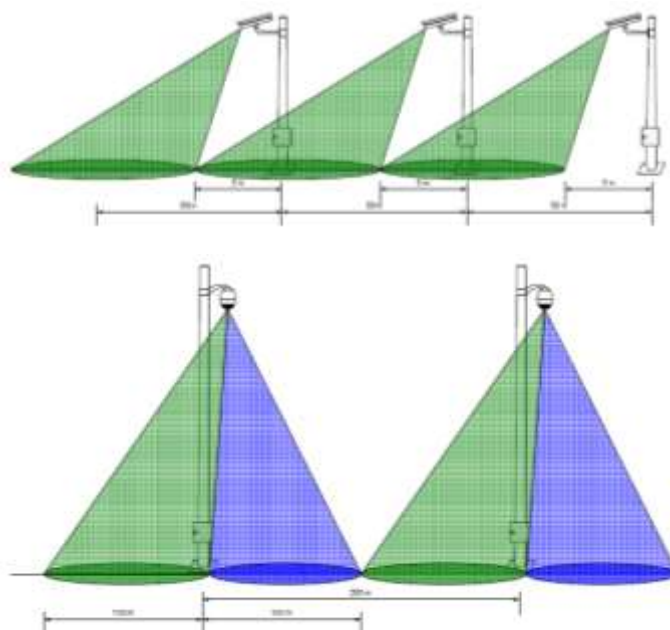

The system will send data allowing the system to be controlled either remotely or locally. The communication net shall be safe, redundant and highly reliable. In case of an internet node is not available, a radio or satellite link will be installed.

Figure 4 – Security Schema

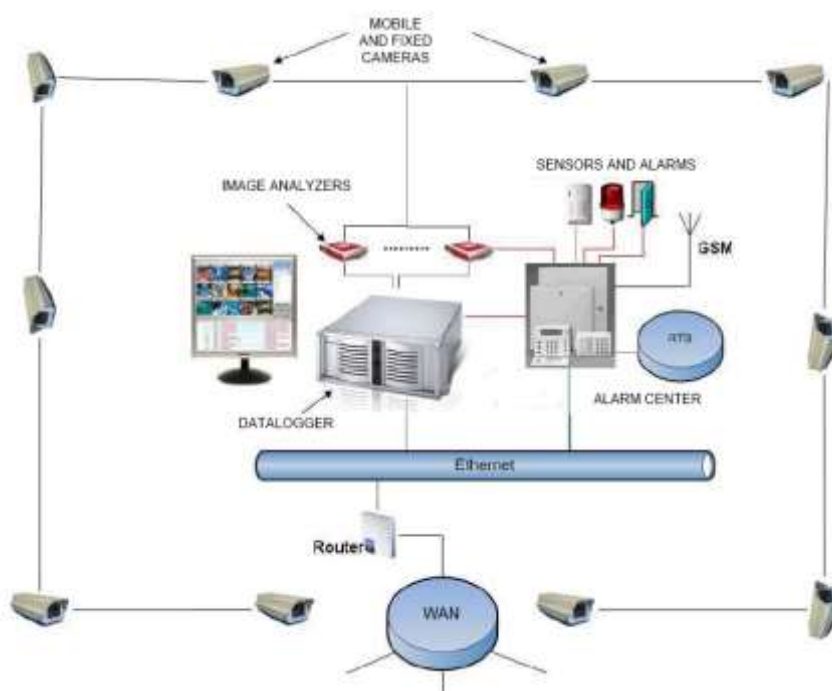



10 MONITORIZATION SYSTEM

It shall be designed in order to achieve a global and detailed view of the operation of the plant and a failure or deviation detection tool.

The data acquisition levels are:

- Junction boxes: measuring voltage and intensity in photovoltaic generators
- Inverters: input and output process variables at the inverter
- Meteorological station
- Measuring counters at the battery limit of the PV plant, in order to know the energy delivered to the electric company.

All these data are sent, by means of a fiber optic net, to the Control Center, where a SCADA application is installed. This SCADA will be continuously evaluating inverter values in order to supervise which are producing with poor performance and to allow corrective actuations.

10.1 Description

The following variables, among others, are monitored:

- Power delivered to the Grid, totalized by months, years or other time scope.
- Grid voltage, intensity and frequency
- Total power of the plant: active and reactive
- Current and voltage per phase.
- Delivered active energy
- Daily energy
- Performance ratio
- Average performance of the plant and compared performance of each string.
- Irradiance, ambient temperature and other relevant meteorological variables.
- Inverter status, maximum power point, energy and power delivered alarms and diagnostics.
- Communication diagnostic and failures supervision.

All these data will be available at the Power Plant Control center as well as remotely using a web site.

The SCADA system shall perform monitored data storage and a daily local back-up copy. Also, an external back-up and data storage will be also done in order to enhance maintenance and availability of the plant.

The SCADA will have several means of data visualization: a general plant view with the most significant values which allow navigating to detailed faceplates for each inverter, string, or meteorological station. It also have available reports, trends and comparisons and alarms logs, in which pre-alarms, confirmed alarms and recognized alarms are stored and identified.



10.2 Equipment

- Meteorological station: includes measurement of temperature, atmospheric pressure, wind, humidity, rain, and solar irradiation sensors (pyranometers). Meteorological station will be mounted on tower of 6 m. height.
- Counter for plant output.
- Grid analyzer, to measure voltage, current, frequency, harmonics, reactive power, impedance. Main purpose of this device is the analysis of the quality of the link plant grid.
- Data loggers.
- System of communications plant-client, it works with the protocols of communications supplied in meteorological station, grid analyzer, inverters, and with data provided from the points chosen by the client.
- Communications with the client, and with maintenance service. It can be through ADSL, 3G, and GSM. Apart from the system for the client, another communication system for grid manager will be installed. This will report the required measurements by the company, through modem, via ADSL, 3G, GSM. This communication system will allow grid manager remote control over every switch located at MV side of every transformer, in order to disconnect/reconnect them if necessary. Wiring of this will be made with optical fiber. Devices of both systems can be located in the cabin for point of connection, next to counter.
- Server based on PC, with redundant hard disc, DVD recorder, and monitor, mounted on rack.
- UPS with automatic reboot
- Windows operative system, SQL server and VNC tools.
- For O&M activities, a local operation workstation will be installed on site.
- Inside inverter building, the following equipment will be installed:
 - PLCs for local control
 - F.O switch
 - UPS
 - RS485-TCP/IP gateways.

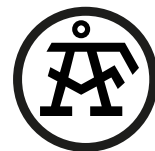
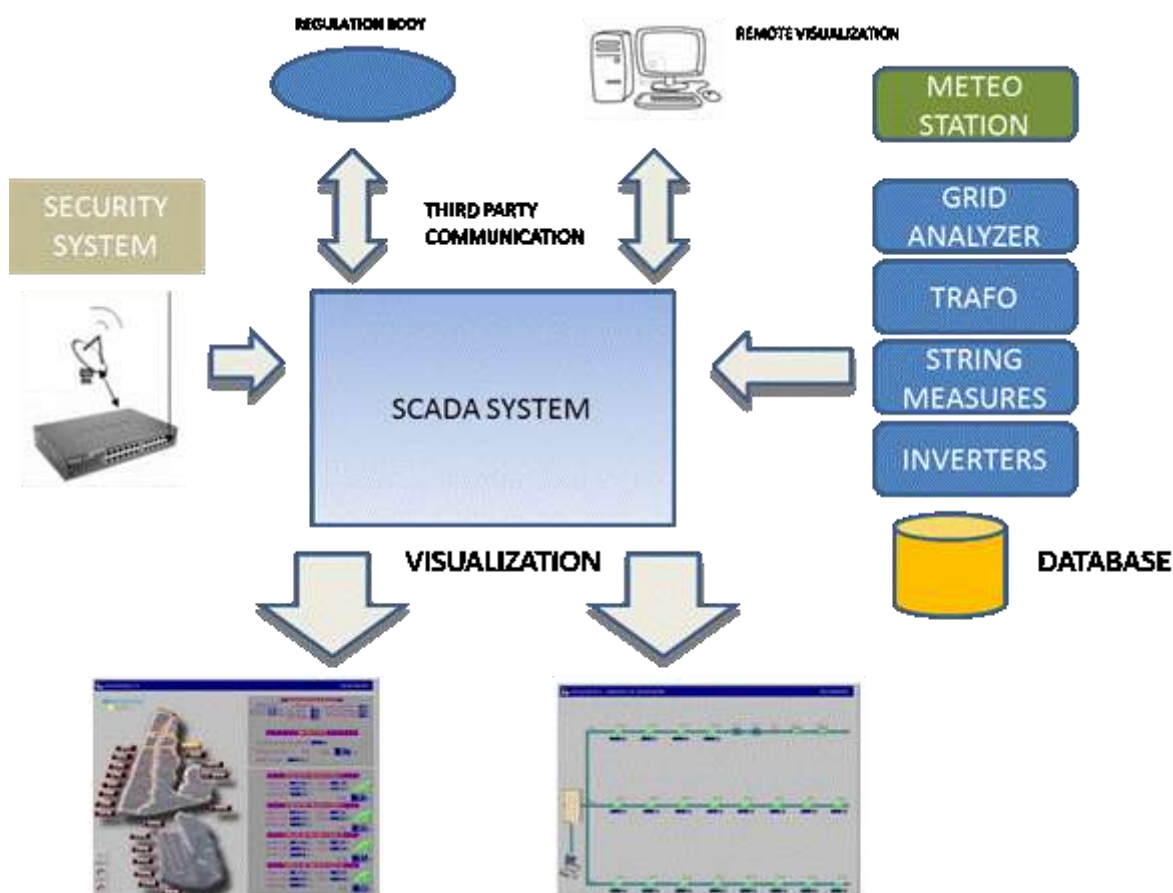

Figure 5 – Monitorization System Schema



10.2.1 Meteorological station

Meteorological station shall allow the measurement of all type of meteorological variables, data treatment and storage, and provide versatility for communications, local and remote configuration and programming. Accordingly open communication protocol shall be provided.

Station will be specially designed for outdoors installation, in remote unattended areas

For data storage and internal data logger for 3 months data storage shall be included, external SD card shall be included also, at least 32 GB. All measured variables and instruments status signals shall be stored. Sampling time of data acquisition and storage shall be configurable by the user. Minimum 1 minute.

Meteorological station shall be design to operate with the following power inputs:

- External grid 220V 50Hz
- Internal battery system charged by a solar panel dimensioned for 5 days autonomy

Meteorological station shall accept signal from instrument in the following type:

- 0/4-20 mA current signal
- 0-24 VDC digital input or outputs
- Pulse counter



- Resistance and thermocouple signals.

At least following interfaces and communication protocols shall be supported:

- RS232
- RS485
- GSM/GPRS
- TCP/IP
- Modbus

The meteorological station receives information from the following instruments:

- Temperature:
 - Range -30/+70 °C
 - Accuracy 0.1°C
- Relative humidity
 - Range 0-100%
 - Accuracy +/-3%

Combined sensor for temperature and relative humidity is allowed.
- Rainfall:
 - Technology tilting cups or other state of the art accumulation technology
 - Collector area: 200 cm²
 - Accuracy: 5%
- Ambient pressure
 - Range 600-1100 mb
 - Accuracy +/- 0.3 mb
- Wind
 - Horizontal speed
 - Range 0-50 m/s
 - Accuracy 1 m/s
- Direction
 - Range 0°-360°.
 - Accuracy 2°
- Global radiation (piranometer)
 - ISO 9060 Classification: First class (WMO Good Quality)
 - Range: 0-2000W/m²
 - Spectral response : 305 ~ 2800nm
 - Response time : approx. 5 sec. (95% response)
 - Field-of-view : 2π steradian
 - Sensitivity : approx. 7-14μV/W·m²



11 CIVIL WORKS DESCRIPTION

11.1 Earth movements

The PV plant is divided in two land plots which are one next to each other so it can be considered as one final plot for the plant. The total area occupied by 19.40MW_P PV plant is approximately 344463 m², with the distribution shown in the following figure:

Figure 6 – Occupied area

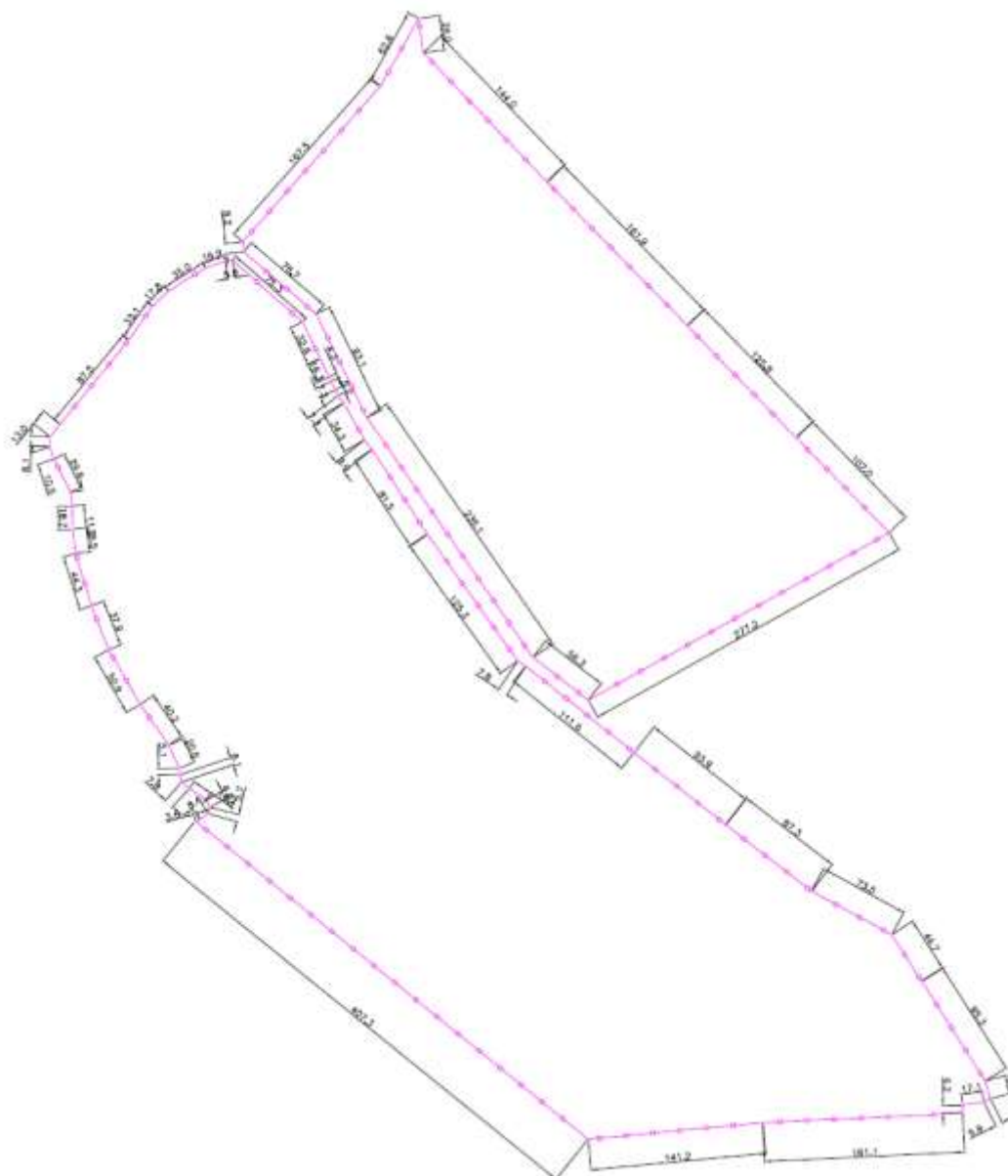

Alignment and slope allowable in the terrain shall fulfill the requirements of the photovoltaic provider.

The area shall be free of obstacles and it will be horizontal, stable and with adequate dimensions to allow movement of vehicles employed in the civil works.



If it is necessary, it will be cleared the vegetable layer. If the land will not be enough strong, there will be prepared an adequately compacted base.

The terrain used for the construction will comply with geotechnical report conditions and should be moisture-conditioned and placed and compacted in accordance with its recommendations.

11.2 Roads

11.2.1 Perimeter road

A perimeter road will be implemented joining the internal roads in the outline of the General Blocks to improve the mobility.

11.2.2 Internal road

The purpose of the internal roads is to allow access to various facilities in the solar plant, during construction, operation and maintenance on a safe way. The internal road connects the perimeter road in the middle of the site.

Considering the hydrology study and drainage system designed in the plant will assess the design of the roads drainage.

11.2.3 Parking area

A parking with capacity of at least 15 vehicles will be necessary. This parking is available in the vicinity Control Center.

The roads will have the appropriate transversal slope for drainage to reduce pending and infiltration of water into the pavement and sub-grade materials. The construction of perimeter swales, edge drains, curbs and gutters, or combination of these drainage devices is recommended to reduce the adverse effects of surface water runoff. The design of the alignment of each road will be carried out adequately to let the vehicles to pass over these roads under safety and comfortable conditions.

The sizing of the type section will be done taking into account the heavy traffic category (number of vehicles per day) and types of soils of the embankment, ensuring the correct transmission of loads during the useful life of the plant.

11.3 Buildings

The following buildings are considered:

11.3.1 Control Center

Prefabricated galvanized steel building (container blocks-type). It will contain an occupation of 12.5m*6m (75m²) approximately, sharing inside a control room, toilet and dressing room, kitchenette and electrical room. It will be available in the vicinity a parking.

11.3.2 Warehouse

Prefabricated galvanized steel building (container blocks-type). It will contain an occupation of 12.5m*6m (75m²) approximately.

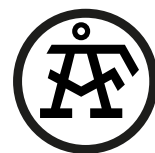

11.3.3 Inverter transformer center (ITC)

Prefabricated galvanized steel building (container-type) with approximately dimensions 6 x 2.5 x 2.9 m (or similar) with one or two inverters, one medium power transformer, one auxiliary power transformer, and all auxiliary elements to lighting, auxiliary power supply, ventilation, security and fire protection.

Figure 7 – ITC Building

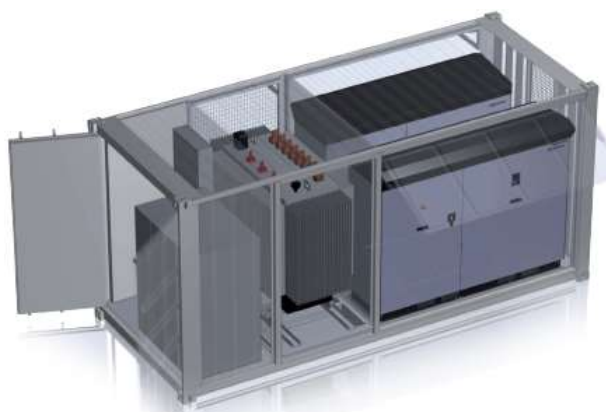

11.3.4 Connection center (CC)

There will be a prefabricated concrete building with approximately dimensions 9.6 x 2.6 x 3.6 m (or similar) with auxiliary medium voltage power transformer, medium voltage switchgears and all auxiliary elements to lighting, auxiliary power supply, ventilation, security and fire protection.

Figure 8 – CC Building



11.4 Structure of photovoltaic modules

According to photovoltaic structures providers the supporting structure (columns, tubes, bars and levers) of photovoltaic modules normally is hot-dip galvanized steel (according to EN ISO 1461). All the elements will be bolted. Welding, drilling or cutting is not necessary on site.

Main structure will be formed by foundation posts and rails, both produced by hot-dip galvanized steel profiles. Two foundation posts will form one support unit. This allows wider support distances and bigger module areas. The PV modules will be horizontally assembly on the rails with the appropriate fastening system to withstand the loads due to the weight of the PV panels and to those generated by weather conditions.



It may ensure an adequate durability strategy and will be considered all possible mechanisms of degradation, identifying these, by the exposure class that defines the aggressiveness of site and thus establishing the most appropriate method of protection, throughout the useful life of the solar plant.

Therefore, the design of a metal structure shall include the measures necessary so that the structure has the useful service life, as a function of the environmental and soil aggressiveness conditions to which it may be subjected. A durability strategy shall therefore be included. Also the metal structures should be designed to requirements of stability and structural analysis.

The following figures describe the supporting structures:

Figure 9 – PV structure Lay-out

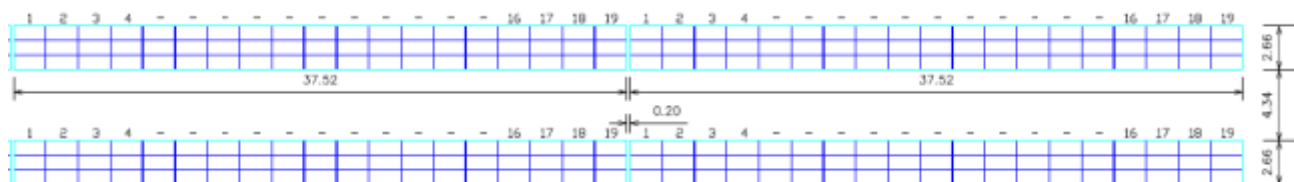
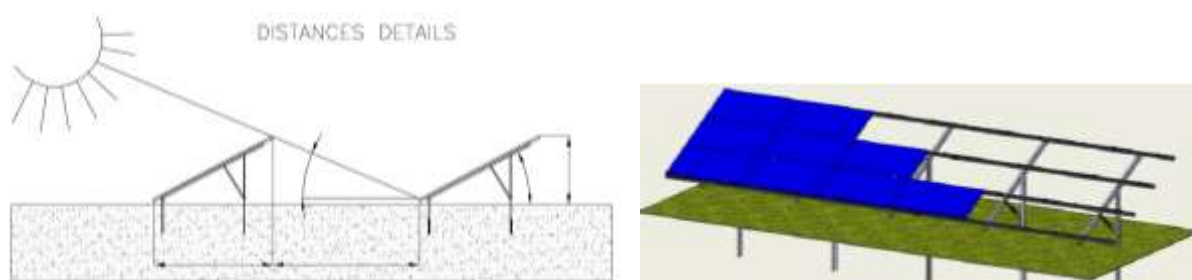

Figure 10 – Views of the PV structure



11.5 Foundations

The foundations depend on the structure itself, the wind requirements, the terrain characteristics, and the good durability strategy. For this reason there is not a general optimal solution and it always depends on the combination of the mentioned factors.

In later stages of the project, the choice of the type, shape and size will be handled as well as the structure type for supports and the loads transmitted to the foundation, taking into account the existing conditions the geological and geotechnical study of the location.

In any case, will be performed a geotechnical design of foundations with tolerable settlements ensuring a sufficient security against sinking collapse. Ensuring, at all times, an adequate strategy of durability for the service life of the solar plant.

11.5.1 Photovoltaic structure

As a guide it may be mentioned that the foundations for the steel structure of photovoltaic modules generally are reinforced concrete footing or pile. Other solution possible is drive steel profiles and screw krinner, but not all soils allow it

Alignment and allowable displacements (horizontal, vertical, angular deviation) in photovoltaic foundation shall fulfill the requirements of the provider.



Figure 11 – Krinner screw, reinforced concrete foundation and drive steel profile

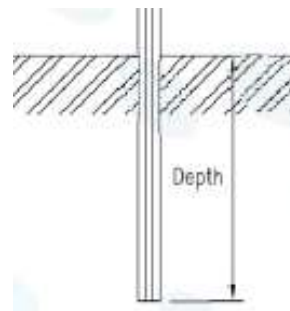
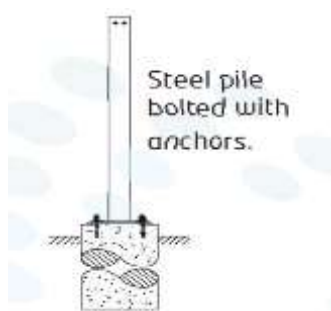
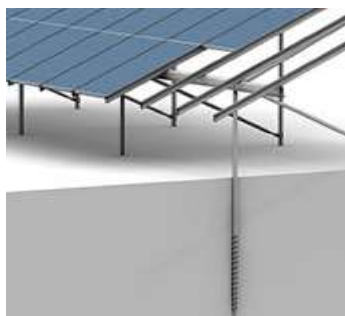

11.5.2 CC facilities

As a guide it may be mentioned for the CC, usually, the building slabs serves as foundation, preparing the contact area with a sand bed.

Figure 12 – Typical sketch



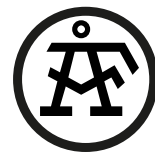

11.5.3 ITCs, Control building and Warehouse foundations

As guide it may be mentioned that the foundations will be direct of reinforced concrete.

Figure 13 – ITC foundation

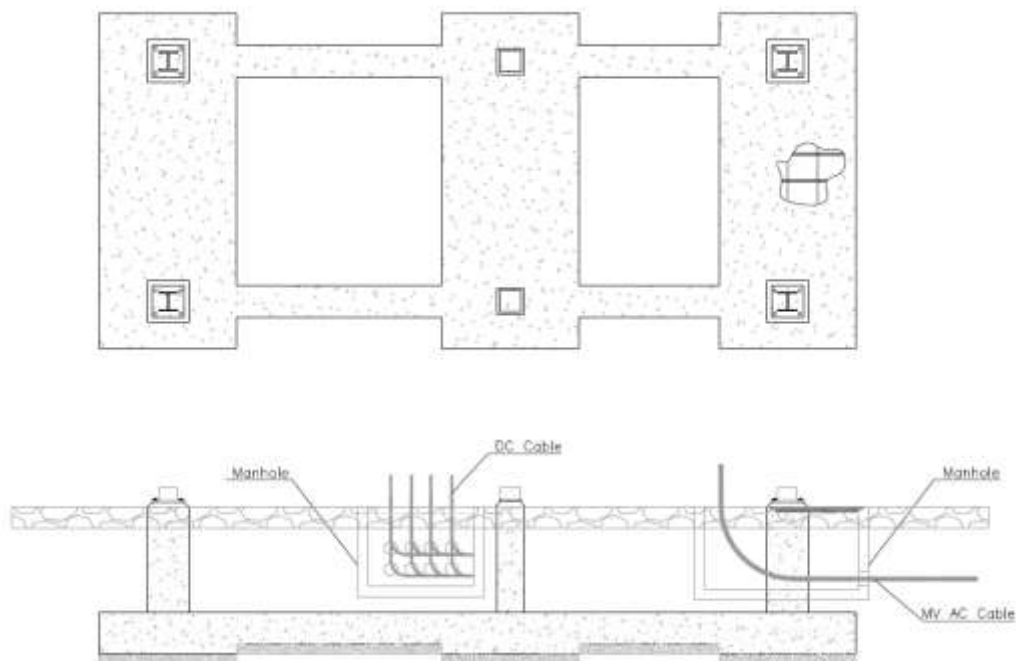
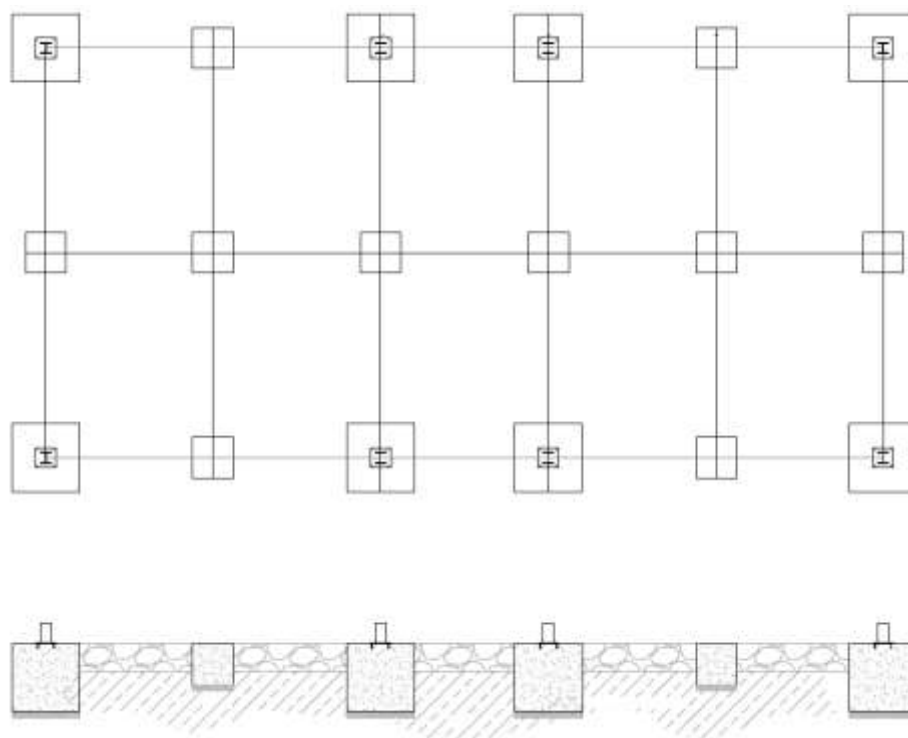

Figure 14 – Control Center and Warehouse foundation





11.6 Drainage

A philosophy of drainage will be previously evaluated according to the site conditions that allow to decide the need of protection of the plant against floods, avoiding damage to people and facilities during the phases of construction, operation and maintenance.

11.7 Perimeter fence

Perimeter enclosure will be erected a perimeter fence 2m height with strands of barbed wire for security, with steel posts separated adequately and steel post reinforcement each 15 m and in each direction change. A galvanized steel wire mesh of simple twist at least, will be placed between the steel posts. Steel posts must be adequately installed on the ground for proper working of the fence. It will be taken into account the location of the accesses for the vehicles and pedestrians.

The perimeter fence will meet the environmental conditions.

11.8 Water system

The supply of fresh water can be performed via public network, water wells or water supply to the PV plant by trucks. Central or decentralized local network(s) on the PV plant can be developed and installed.

Water supply and distribution system have to be installed for all water needed including for module cleaning, potable water and fire fighting systems.

For the PV plant of Masrik 2 it has be estimated around 340 m³ per year of water for the O&M labors of PV modules cleaning, and around 51 m³ per year of water for the O&M staff.

The total consumption of water per year is estimated in about 391 m³, which it involves around 32 tank trucks of 10000 liters of capacity, in case that public water network or water wells don't be available.



12 COST ESTIMATION

Cost estimation has been performed in order to show CAPEX & OPEX of the plant based on ARIES worldwide experience in other similar PV plants and on internal databases, as well as on the international market tendencies.

Due to project time schedule and estimation nature, costs may suffer variations when supplier negotiations are carried out in order to optimized plant costs and increase CAPEX and OPEX accuracy.

All equipment estimated costs are international market standard costs.

The following item cost is included in CAPEX (include both equipment and labor cost):

- EPC cost
 - Main equipment supply:
 - Modules.
 - Inverters, medium voltage transformers and MV switchgears (Power block).
 - Mounting structure.
 - Combiner boxes.
 - MV connection center.
 - Wires supply:
 - Electrical wiring.
 - Grounding.
 - Evacuation facilities:
 - Substation.
 - Evacuation line.
 - Monitoring and security system
 - Installation works:
 - Civil works (including earth movement, urbanization and roads).
 - Equipment and wiring installation.
 - Other items:
 - Spare parts.
 - Engineering & project management.
 - Contingencies (3% EPC cost).
 - EPC profit (10% EPC cost).

Typical EPC profit for this kind of projects ranges within 7%-12%, with 10% as a common value.

- Developer cost:
 - Permitting, licensing and legal.



- Owner's engineering.
- Project management and advisor's fees.
- Insurances.
- Pre-construction cost.
- Land.

Developer cost has been estimated based on similar projects. However this is a very project specific item that depends on the site legal, permitting and normative scenarios of the country. Therefore it is just estimated and should be fully analyzed in development phase.

Regarding OPEX estimation, the following lines show items breakdown considered:

- Salaries.
- Surveillance.
- Communications.
- Consumables:
 - Electrical consumption.
 - Water consumption.
- O&M management.
- Insurances.
- Contingency.

For salaries, ARIES has considered local personnel cost provided by Client as follows:

- Plant manager salary 1500 USD/month.
- Maintenance workers salary 700 USD/month.
- Non qualified personnel salary 250 USD/month.

The following table shows CAPEX and OPEX estimation breakdown:



Table 12 – CAPEX estimation breakdown

ITEM	COST (US DOLLARS)	\$/Wp
Main equipment supply	10.452.899	0,54
Modules	5.725.171	0,30
Power blocks (inverters)	2.037.515	0,10
Structure	2.309.840	0,12
Combiner boxes	218.407	0,01
MV connection center	161.966	0,01
Wiring supply	765.273	0,04
Electrical DC wiring	578.134	0,03
Electrical AC wiring	92.132	0,00
Grounding	95.008	0,00
Evacuation facilities	676.949	0,03
Substation	635.162	0,03
Evacuation line	41.787	0,00
Monitoring & Security system	603.377	0,03
Installation works	4.013.719	0,21
Civil works	2.548.152	0,13
Earth movement	1.180.314	0,06
Trenches and manholes	849.202	0,04
Urbanization (roads, buildings, fence...)	518.635	0,03
Equipment and wiring installation	1.465.567	0,08
Spare parts	187.477	0,01
Engineering & Project Management	412.805	0,02
Contingencies (3% EPC cost)	513.375	0,03
EPC profit (10% EPC cost)	1.762.588	0,09
TOTAL EPC COST	19.388.464	1,00
Development costs	425.442	0,02
Land	106.877	0,01
TOTAL DEVELOPER COST	532.319	0,03
TOTAL CAPEX	19.920.783	1,03



Table 13 – OPEX estimation breakdown

ITEM	COST (US DOLLARS)	\$/Wp
Salaries	72.939	0,004
Surveillance	8.915	0,000
Communications	11.143	0,001
Consumables (electrical water)	12.291	0,001
O&M Management	113.721	0,006
Contingencies	2.190	0,000
Insurances	58.165	0,003
TOTAL OPEX	279.364	0,014



13 FINANCIAL ASSESSMENT

13.1 Introduction

The financial analysis is presented in the current report, of which an overview is provided hereinafter.

Key assumptions for the financial analysis are presented in chapter 13.2. The key assumptions address mainly capital investments and financing, tariffs and ROE targets.

The energy volume projections are addressed in chapter 13.3. The project investments and concerned cost estimates, as well as investment financing aspects are dealt with under chapter 13.4. Operational costs of the project (OPEX) are presented in chapter 13.5.

Project tariffs, revenue, I/S and cash-flow projections are highlighted in chapter 13.6. The financial analysis with the provision of concerned ratios and indicators, as well as a sensitivity analysis are presented in chapter 13.7.

The project conclusions and recommendations are summarized in chapter 13.8.

13.2 Key assumptions

The financial analysis and forecasts for the purpose of this study are based on the key assumptions summarized in the following Table 14.

Table 14 – Key assumptions for financial analysis and forecasts

Nº	Descriptions	Assumptions	Comments
1	Project time horizon	20 years of operations after commissioning of project investments;	
2	CAPEX	CAPEX cost estimates are developed for the envisaged construction year 2017;	
3	Depreciation	20 years depreciation are considered according to the Armenian regulation	
4	OPEX: Cost price escalation factor	A cost price escalation factor has been considered for determining OPEX throughout the projection period, based on cost estimates for the year 2017;	Factor determined based on projected Armenian and USD inflation rate;
5	Tariff	The financial model considers a tariff scenario, which allows the achievement of the targeted IRR of equity indicated hereinafter; throughout the projection period	Tariff fixed flat in US\$ for the whole period. No escalation has been applied.
7	Equity IRR	A target factor of ca. 13 % has been established for the IRR of Equity and determination of the NPV of dividends;	



13.3 Energy volume data projections

For the purpose of the financial analysis the envisaged energy generation projections for the considered generation plant are determined based on the technical indicators presented in the corresponding chapter of this report.

In line with the project projections – for the base performance –, an annual degradation factor of 0.5 % was applied on the number of working hours per year.

A power generation overview for selected years is presented in the following table.

Table 15 – Power generation overview – (GWh).

		2018	2019	2020	2021	2022	2027	2032	2037
Peak capacity	MWp	19,41	19,41	19,41	19,41	19,41	19,41	19,41	19,41
Nominal capacity	MW	16,29	16,29	16,29	16,29	16,29	16,29	16,29	16,29
Hours in the period	hours	1.949	1.939	1.929	1.920	1.910	1.863	1.817	1.772
Energy output	MWh	31.401	31.244	31.088	30.932	30.778	30.016	29.273	28.548

As indicated in above table, the plant generation will be 31.40 GWh in the first production year and 28,54 GWh by the end of the projection period.

13.4 Projections of capital investment costs and financing

13.4.1 Project investments and cost estimates (CAPEX)

The financial analysis is presenting data for the project scenario as defined in the corresponding chapter of the current report, whereby proposed investment costs have been taken into consideration.

The project investment cost estimates (cost base: year 2017) are determined in line with the methodology presented in the relevant chapter of this report. The principal CAPEX components concern equipment, civil works and engineering and other costs. Investment related VAT charges will be recovered during the projection period.

An overall capital investment cost summary is shown in the following table.



Table 16 – INVESTMENT COST

	TOTAL CAPEX (US\$)
Engineering and works management	514.087
Equipment	11.617.514
Imported	11.617.514
Local	-
Civil works, installations and BOP	5.920.606
Civil works	2.802.967
Installations	1.612.124
BOP	1.505.516
Grid Connection	744.644
Contingencies	639.594
Import duties	-
EPC cost	19.436.446
Development costs	443.439
Land	106.877
VAT	-
Total CAPEX	19.986.762

TOTAL INVESTMENT COST	US\$	20.589.435
CAPEX	US\$	19.986.762
Working capital	US\$	23.595
Commitment/front-end fees and interest during construction	US\$	579.078
Interest	US\$	501.867
Front-end fee	US\$	-
Commitment fee	US\$	77.210

As highlighted in above table, the total project capital investment volume is estimated at \$20,58 M.

13.4.2 Financing of project investments

The project CAPEX financing is envisaged to be performed by commercial banks and equity.

For the base case, (scenario 1) the overall financing scenario of the current project is summarised in the following table.



Table 17 – Overall project financing scenario

Sources of funding	
Equity	\$ 5.147.359
Debt	\$ 15.442.077
Total	\$ 20.589.435

Sources of debt financing	
IBRD loan	-
SREP credit	-
IBRD guarantee covered commercial	-
Uncovered commercial	15.442.077
Total debt financing	15.442.077

The relevant Debt conditions are summarized in the following table.

Table 18 –Summary of loan conditions

		Uncovered commercial
% of Total debt financing	%	100%
Amount of financing	US\$	15.442.077
Maturity	Yrs	12
Grace period	Yrs	1
Fixed rate	%	6,50%
Margin	%	0,00%
Front-end fee	%	0,00%
Commitment fee	%	0,50%

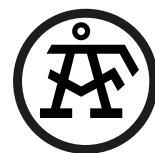

13.5 Projections of Operational Costs

13.5.1 OPEX

In line with the OPEX cost estimates presented in the corresponding chapter of the current report, the project scenario envisages the following main cost components: An OPEX cost overview for selected years is presented in the following table.

Table 19 – OPEX cost – (US\$)

		2018	2019	2020	2021	2022	2027	2032	2037
Operating and maintenance costs	US\$/Wp	(301.610)	(309.150)	(316.879)	(324.801)	(332.921)	(376.670)	(426.167)	(482.169)
Salaries	US\$/Wp	(76.632)	(78.548)	(80.511)	(82.524)	(84.587)	(95.703)	(108.279)	(122.508)
International qualified	US\$/Wp	(18.911)	(19.384)	(19.869)	(20.365)	(20.874)	(23.618)	(26.721)	(30.232)
Local qualified	US\$/Wp	(26.476)	(27.138)	(27.816)	(28.511)	(29.224)	(33.065)	(37.410)	(42.325)
Local non-qualified	US\$/Wp	(31.245)	(32.026)	(32.827)	(33.647)	(34.488)	(39.021)	(44.148)	(49.950)
Spare parts and supplies	US\$/Wp	(33.986)	(34.836)	(35.707)	(36.599)	(37.514)	(42.444)	(48.022)	(54.332)
Insurance and others	US\$/Wp	(190.992)	(195.767)	(200.661)	(205.677)	(210.819)	(238.523)	(269.867)	(305.329)

The OPEX cost estimates consider an impact of inflation on local and international costs throughout the projection period.

13.6 Tariffs, revenue projections, I/S and Cash-Flow

13.6.1 Tariff calculation scenarios

The financial model incorporates a tariff calculation modality in order to achieve a targeted 13% Shareholders' equity throughout the projection period.

The tariff base scenario is a flat tariff which does not foresee a tariff growth rate throughout the entire period.

A flat tariff of US\$ cents 9,76 per kWh (excluding VAT) is estimated for the whole 20 years period.

13.6.2 Revenue projections

In line with the energy volume data projections presented in chapter 13.3 and the tariff calculation scenario described in chapter 13.6.1, the revenue figures have been projected.

A revenue overview for selected years is presented in the following table.



Table 20 – Revenue overview

		2018	2019	2020	2021	2022	2027	2032	2037
Peak capacity	MWp	19,41	19,41	19,41	19,41	19,41	19,41	19,41	19,41
Nominal capacity	MW	16,29	16,29	16,29	16,29	16,29	16,29	16,29	16,29
Hours in the period	hours	1.949	1.939	1.929	1.920	1.910	1.863	1.817	1.772
Energy output	MWh	31.401	31.244	31.088	30.932	30.778	30.016	29.273	28.548
CPI	Index	105%	108%	110%	113%	116%	131%	148%	168%
Tariff, incl. VAT	US\$/kWh	0,117	0,117	0,117	0,117	0,117	0,117	0,117	0,117
Revenue	US\$	3.687.491	3.669.054	3.650.708	3.632.455	3.614.293	3.524.834	3.437.590	3.352.506
	VAT US\$	(614.582)	(611.509)	(608.451)	(605.409)	(602.382)	(587.472)	(572.932)	(558.751)
Net Revenue	US\$	3.072.909	3.057.545	3.042.257	3.027.046	3.011.910	2.937.362	2.864.659	2.793.755

As presented in above table, the annual net revenues will vary only very slightly throughout the projection period as a consequence of the applied degradation factor.

13.6.3 Projections of I/S

The I/S projections of the Financial Model present the following main elements:

- Income,
- OPEX,
- Financial expenditures, and
- Income taxes

Details of highlighted main elements are presented in previous chapters of this report to which reference is being made.

An I/S projections overview for selected years is presented in the following table.

Table 21 – I/S projections overview

		2018	2019	2020	2021	2022	2027	2032	2037
Net Revenue	US\$	3.072.909	3.057.545	3.042.257	3.027.046	3.011.910	2.937.362	2.864.659	2.793.755
Operating and maintenance costs	US\$/Wp	(301.610)	(309.150)	(316.879)	(324.801)	(332.921)	(376.670)	(426.167)	(482.169)
EBITDA	US\$	2.771.299	2.748.395	2.725.378	2.702.245	2.678.990	2.560.692	2.438.492	2.311.586
Depreciation	US\$	(1.022.948)	(1.022.948)	(1.022.948)	(1.022.948)	(1.022.948)	(1.022.948)	(1.022.948)	(1.022.948)
EBIT	US\$	1.748.351	1.725.446	1.702.430	1.679.297	1.656.041	1.537.744	1.415.543	1.288.638
Interest expense	US\$	(958.111)	(866.862)	(775.613)	(684.365)	(593.116)	(136.873)	(0)	(0)
EBT	US\$	790.241	858.584	926.817	994.932	1.062.925	1.400.871	1.415.543	1.288.638
Corporate tax	US\$	(158.048)	(171.717)	(185.363)	(198.986)	(212.585)	(280.174)	(283.109)	(257.728)
Net profit	US\$	632.192	686.867	741.453	795.946	850.340	1.120.697	1.132.435	1.030.910

The net income is gradually increasing during the first 20 years of the projection period. Subsequently, and as a consequence of debt service reduction.

The Corporate Income Tax is determined at a rate of 20% of taxable income in line with national regulations.



13.6.4 Cash flow projections

The projections of the project cash flow consider the following main components in line with the I/S model, but adjusted by elements in order to comply with cash flow criteria.

An overview of cash flow projections for selected years is presented in the following table.

Table 22 – Overview of cash flow projections (USD)

	2017	2018	2019	2020	2021	2022	2027	2032	2037
	1	2	3	4	5	6	11	16	21
Project period flag	1	1	1	1	1	1	1	1	1
OPERATING CASH FLOWS									
Net profit	-	632.192	686.867	741.453	795.946	850.340	1.120.697	1.132.435	1.030.910
[+] Depreciation	-	1.022.948	1.022.948	1.022.948	1.022.948	1.022.948	1.022.948	1.022.948	1.022.948
[+] Interest expense	-	958.111	866.862	775.613	684.365	593.116	136.873	0	0
[+/-] Decrease/Increase in net working capital	-	(429.832)	2.893	2.897	2.902	2.907	2.939	2.984	3.044
[+/-] Decrease/increase in tax assets	-	-	-	-	-	-	-	-	-
After-tax operating cash flows	-	2.183.419	2.579.571	2.542.912	2.506.160	2.469.311	2.283.457	2.158.367	2.056.902
INVESTMENT CASH FLOWS									
Capital expenditure	(19.986.762)								
Financing cost	(579.078)								
Total investment cash flows	(20.565.840)								
FINANCING CASH FLOWS									
Equity funding	5.147.359								
Debt funding	15.442.077								
Interest payment	-	(958.111)	(866.862)	(775.613)	(684.365)	(593.116)	(136.873)	(0)	(0)
Principal payment	-	(1.403.825)	(1.403.825)	(1.403.825)	(1.403.825)	(1.403.825)	(1.403.825)	-	-
Total financing cash flows	20.589.435	(2.361.936)	(2.270.687)	(2.179.439)	(2.088.190)	(1.996.941)	(1.540.698)	(0)	(0)
Net cash flows	23.595	(178.517)	308.883	363.473	417.970	472.370	742.759	2.158.367	2.056.902

An important element of the cash flow analysis is the project's capacity to generate sufficient financial resources in order to attend the debt service requirements. The concerned project indicators are presented hereinafter:

Table 23 – I/S DSCR projections

	2017	2018	2019	2020	2021	2022	2027	2032	2037
DSCR	N/A	0,92	1,14	1,17	1,20	1,24	1,48	N/A	N/A
Min DSCR	0,92								
Average DSCR	1,28								

Consequently, the achieved average DSCR guarantees the project financiers an adequate overall debt service ratio, although a low DSCR would occur the first year which would be easy to assess during the final structuring of the Project.

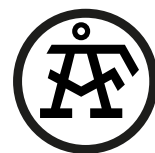

13.7 Financial Scenarios

13.7.1 General aspects of financial analysis

Different CAPEX financial scenarios were considered according to the conversations with the client and with the WB. The scenarios and the resulting tariff are shown in the following table:

Costs in MUS\$	Scenario 1: Public project	Scenario 2: Private project with World Bank guarantee (for termination payment)	Scenario 3: Fully private project
EPC, development, land acquisition, and financing costs (in MUS\$)	20.25	20.49	20.59
Equity (in MUS\$)	5.06	5.12	5.15
Concessional sovereign-guaranteed loan	15.19	0	0
Uncovered commercial debt (in MUS\$)	0	5.56	15.44
Covered commercial debt (in MUS\$)	0	9.81	0
Estimated tariff in USc/kWh (VAT exclusive)	6.42	9.40	9.76

The base case (Scenario 3) shows fully commercial financing, Scenario 2 shows finance using 64% of Commercial Debt covered with a World Bank Guarantee and 36% of uncovered commercial loan, and Scenario 1 shows fully multilateral-concessional financing.

13.7.2 Sensitivity Analysis

A number of factors can influence the results situation, cash flows and the conclusions of the base case scenario. In order to test the soundness of the base case analysis several adjustments have been made to key variables. The testing was performed on several selected individual factors.

The following sensitivity tests on individual factors were performed:

- Increase and decrease of projected investment costs, and
- Variation of Debt/equity Ratio
- Variation of Equity Remuneration.



13.7.2.1 Increase and decrease of projected investment costs

We have assessed the impact of increase or decrease of project CAPEX. The results are shown in the following table:

Table 24 – Impact of CAPEX variation

CAPEX	Tariff US\$ cents/kWh
CAPEX +20%	11.44
CAPEX +10%	10.61
Base Case	9.76
CAPEX -10%	8.95
CAPEX -20%	8.11

As PV cost is historically lowering, it is expected a reduction of capex by 2018. However, some other socio-economic factors can affect and make CAPEX grow in the future. The impact of both cases are shown in the table.

13.7.2.2 Variation of Debt/equity Ratio

We have assessed the impact of Different level of leverages by investors. The results are shown in the following table:

Table 25 – Impact of D/E ratio variation

Debt Equity ratio	Debt	Equity	Tariff (USDc/kWh)
Scenario A	80%	20%	9.60
Base Case	75%	25%	9.76
Scenario B	70%	30%	9.94
Scenario C	60%	40%	10.27

13.7.2.3 Variation of Equity Remuneration

We have assessed the impact of Different level of remuneration to equity investors. The results are shown in the following table:

Table 26 – Impact of equity remuneration

Scenario	Equity IRR	Tariff
Base Case	13%	9.76
Scenario I	10%	8.83
Scenario II	20%	11.89



13.8 Conclusions and recommendations

The project is feasible from the financial point of view, although having a slightly high tariff for the electricity. It is important to highlight that the estimated tariff is “flat type” so no actualization is considered in the value for the whole life of the plant, which implies that the first years is higher than a tariff linked to any cost performance index but, on the opposite side, the last years is lower.

In any case, in order to reduce the tariff amount, it is suggested to prepare a sound legal framework to help the developers to reduce the profit required which, as shown in the sensitivity analysis, may have a strong impact.

On top of this, it is paramount to design a proper bidding process to achieve a high level of competition which could optimize the estimated investment costs and reduce the tariff.



14 DRAWINGS

Table 27 – Drawings

CODE	TITLE	REV.
PEF2827-069-Masrik 2-LOC	General Situation	0
PEF2827-020-Masrik 2 Layout	General Layout	2
PEF2827-065-Masrik 2-BLOCK LAY	Block layout	0
PEF2827-067-Masrik 2-ROADS	Access and Internal Roads	0
PEF2827-068-Masrik 2-MV LINE LAY	Medium Voltage Lines Layout	0
PEF2827-070-Masrik 2-DC SLD	DC Single Line Diagram	0
PEF2827-066-Masrik 2-MV SLD	Medium Voltage Single Line Diagram	0
PEF2827-071-Masrik 2-ITC BUILD	Inverter Transformer Center Building	0
PEF2827-072-Masrik 2-WARE&CB BUILD	Warehouse & Control Building	0
PEF2827-074-Masrik 2-CC BUILD	Connection Center Building	0
PEF2827-075-Masrik 2-GRND	General Grounding	0
PEF2827-073-Masrik 2-MV CONNECT SLD	Interconnection Single Line Diagram	0
PEF2827-120-Masrik 2-OHL ROUTE	Overhead Transmission Line	0
PEF2827-054-Masrik 2-Topographic map	Topographic map	0



15 ANNEXES

Table 28 – Annexes

CODE	TITLE	REV.
14.1 EN-JKM320P-72(4BB)	Module data sheet	0
14.2 INGECON SUN 1165TL B420 Outdoor	Inverter data sheet	0
14.3 R02-LOE-130409	Meteorological station datasheet	0
14.4 Masrik 2 EYA	Energy Yield Assessment	0
14.5 PEF2827-119-Masrik 2-BOM	Bill of materials	1
14.6 PEF2827-124-Risks Matrix	Risk Matrix	0