



FEASIBILITY STUDY 12.5MWp DASHTADEM 1 PV PLANT DASHTADEM-TALIN (ARMENIA)

Prepared by

ÁF-Aries Energía, S.L.

April 2017



Content

1	EXECUTIVE SUMMARY	4
2	CODES AND STANDARDS.....	5
3	SITE LOCATION.....	6
4	GENERAL DESCRIPTION	7
5	SOLAR RESOURCE ANALYSIS	9
6	ENERGY YIELD ASSESSMENT	11
6.1	Model inputs and assumptions.....	11
6.2	Glossary of terms	12
6.3	Performance results	14
7	INSTALLATION DESCRIPTION.....	14
7.1	Generating System	14
7.2	Modules	15
7.3	Inverters	16
7.4	Combiner boxes or junction boxes.....	17
7.5	Generation Medium voltage transformers.....	17
7.6	Auxiliary Medium voltage transformers	18
7.7	Low voltage Cable.....	18
7.8	MV AC Cable.....	21
7.9	Switchgears.....	21
7.10	Grounding General Description	22
7.11	Auxiliary Services	23
7.12	Essential Services	23
8	EVACUATION POWER LINE	24
8.1	Transmission line main characteristics	25
8.2	General description of 10kV line elements.....	25



9	SURVEILLANCE SYSTEM	27
10	MONITORIZATION SYSTEM	29
10.1	Description	29
10.2	Equipment	29
11	CIVIL WORKS DESCRIPTION.....	33
11.1	Earth movements	33
11.2	Roads	34
11.3	Buildings.....	34
11.4	Structure of photovoltaic modules.....	35
11.5	Foundations.....	36
11.6	Drainage	39
11.7	Perimeter fence	39
11.8	Water system	39
12	COST ESTIMATION	40
13	FINANCIAL ASSESSMENT	43
13.1	Introduction	43
13.2	Key assumptions	43
13.3	Energy volume data projections	44
13.4	Projections of capital investment costs and financing	45
13.5	Projections of Operational Costs.....	46
13.6	Tariffs, revenue projections, I/S and Cash-Flow	47
13.7	Financial Scenarios	49
13.8	Conclusions and recommendations.....	51
14	DRAWINGS	52
15	ANNEXES	53

© Copyright



1 EXECUTIVE SUMMARY

The present document describes the result of the feasibility study prepared for a Solar PV 10.47 MW power plant located in the municipality of Dashtadem-Talin. These works are part of the activities carried out by Aries for the Armenia Renewable Resources and Energy Efficiency Fund (henceforth the Client) within the contract "Feasibility Study and Transaction Advisory Services for Preparation of Utility-Scale Power Project".

The land plot used for the study was selected during the previous stages of the project based on meteorological, topographical, environmental and other characteristics, as well as shape, available area and accesses, in order to optimize the development of the project.

Apart from a revision of the available sources of information about the site and several site visits, a topographical desktop study and a geotechnical field study has been carried out to confirm the suitability of the land. The present revision of the report includes the topographical map, but regarding geotechnical tests the results have not yet been received. A new revision will be issued once the results of the tests are received.

During the previous stages of the project, a preliminary assessment of the technology was carried out considering fixed versus single axis tracking technology. The result showed that there was a minor improvement in the cost of electricity for the one axis tracking structure. In any case it was agreed with the Client to consider fixed structures for the design because the improvement in the electricity cost for the tracking technology was very low and it had other disadvantages like higher risk and higher area needed.

ARIES has rendered a plant design, including its grid connection infrastructure, adjusted to the specific characteristics of the Site, in order to assess the feasibility of a PV plant in the selected Site.

The proposed design consists of 4 units with nominal output power of 2.3MW plus one unit with nominal output power of 1.2 MW, each one formed by several parallel and series associations of photovoltaic modules, which in turn are mounted on fixed structures with horizontal PV module assembly.

Using this design, the Typical Meteorological Year of the area provided by the Client and modelling the characteristics of the surrounding obstacles, the plant performance and production has been calculated showing a capacity factor of 23% which is a quite good result for this kind of technology.

An estimation of the cost has also been included, taking into account the proposed design and the international and local market prices and tendencies.

Considering the estimated costs and production, as well as the financial structure and conditions expected for the project, a financial assessment has been rendered with a result of US\$ cents 9,63 per kWh ("flat tariff type").

The result shows that the project is feasible from the financial point of view. It is suggested to prepare a sound legal framework to help the developers to reduce the profit required which may have a strong impact.

On top of this, it is paramount to design a proper bidding process to achieve a high level of competition which could optimize the estimated investment costs and reduce the tariff.



2 CODES AND STANDARDS

PV Farm Project will be designed according to the technical and legal regulations currently in force in Armenia.

It must comply with applicable Armenian laws and regulations, national, regional or local level, and the regulations or directives of the International Electrotechnical Commission apply force at the time of order placement

- IEC 60904-1: Photovoltaic devices
- IEC 61683: Photovoltaic systems - Power conditioners - Procedure for measuring efficiency
- IEC 61727: Photovoltaic (PV) systems - Characteristics of the utility interface
- IEC 61730: Photovoltaic (PV) module safety qualification
- IEC 62093: Balance-of-system components for photovoltaic systems - Design qualification natural environments
- IEC 62124: Photovoltaic (PV) stand alone systems - Design verification
- IEC 61557-1: Electrical safety in low voltage distribution systems up to 1000 V a.c. and 1500 V d.c
- IEC 61558: Specification for safety of power transformers, power supply units and similar apparatus
- IEC 61173: Over-voltage protection for photovoltaic (PV) power generating systems
- IEC 61194: Characteristic parameters of stand-alone photovoltaic (PV) systems
- IEC 61724: Photovoltaic system performance monitoring - Guidelines for measurement, data exchange and analysis
- IEC 62446: Grid connected photovoltaic systems - Minimum requirements for system documentation, commissioning tests and inspection
- ISO 9355-1: Ergonomic requirements for the design of displays and control actuators

Applicable editions of these standards will be the last published, including corrections, at the time of order placement

In case of conflict between standards, the most stringent requirements will prevail.



3 SITE LOCATION

The preliminary site analysis results indicate that the selected area for the photovoltaic plant is suitable: good solar resource, good communication infrastructures, adequate orientation, without environmental constraints and free from trees or any kind of building which could produce shadows, decreasing the performance ratio of the photovoltaic modules.

The site data are:

- Location: Dashtadem-Talin, Aragatsotn Province (Armenia)
- Geographical coordinates and altitude:
 - Latitude: 40° 20.305' N.
 - Longitude: 43° 50.307' E.
 - Altitude: 1400 m above sea level.

Figure 1 – Site location (Source: Google Earth)



This analysis is described in the following sections.

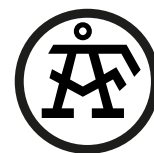

4 GENERAL DESCRIPTION

The net power capacity of PV plant is 10.47MW (AC) with a peak power installed of 12.47MWp and ratio DC/AC 1.19.

The photovoltaic system consists of 4 units with nominal output power of 2.3MW (General Block-2.3MW) and 1 unit with nominal output power of 1.2 MW (General Block-1.2MW). These production units (hereafter ITC "Inverter Transformer Center") are formed by several parallel and series associations of photovoltaic modules, which in turn are mounted on a fixed structure.

- ITC contains following MV switchgear:
 - 1 Incoming switchgear.
 - 1 Outgoing switchgear.
 - 1 Protection switchgear.

As stated in document PEF2827-005-Preliminary Feasibility Study, the differences between fixed structures and tracking systems are the following:

- Fixed structure requires less area per MW.
- The cost of the structure increases from fixed structures to tracking systems.
- The global performance of PV plants with solar tracking systems is greater than PV plants with fixed structures.
- The installation of fixed structure is easier than tracking systems.
- The construction period of a plant with tracking systems is considerably larger than fixed structures.
- The LCOE (Levelized Cost Of Electricity) is lower in PV plants designed with solar tracker system than in PV plants designed with fixed structure.
- O&M in PV plants with fixed structure is easier than PV plants with tracker systems.
- The availability of a fixed structure plant is higher than PV plants with tracker systems.
- Risks of damage of a PV plant are higher with tracking structure.
- Fixed structures are much more resistant to wind than tracking structures.
- Tracking structures increase in auxiliary electricity consumption.

This feasibility study has been developed with fixed structure, but the final design of the PV plant can be made with any of the types at bidder's choice to find their optimum configuration at any case.

Fixed structures will be formed 3 rows of 19 PV panels (57 PV panels per structure) and it will be south oriented.

- General Block – 2.3MW

There will be connected 152 PV fixed structures of 3 rows with 19 PV panels per 2.3MW ITC (8664 PV panels).

Each 2.3MW ITC has two 1164kW inverters. Solar inverters are used to convert the direct current generated by PV modules into alternating current of low voltage. A double secondary power transformer (one secondary winding for each inverter) will raise it to medium voltage under optimal conditions of voltage and frequency for grid connection.

- General Block – 1.2MW



There will be connected 76 PV fixed structures of 3 rows with 19 PV panels per 1.2MW ITC (4332 PV panels).

The 1.2MW ITC has one 1164kW inverter. Solar inverters are used to convert the direct current generated by PV modules into alternating current of low voltage. A single secondary power transformer will raise it to medium voltage under optimal conditions of voltage and frequency for grid connection.

Each ITC will be equipped with an auxiliary power transformer which will supply energy to necessary auxiliary services for proper operating of PV plant (inverter power supply, lighting, monitoring, power suppliers, etc...).

The interconnection of the 5 production units that composed the PV Plant will be by 1 circuit of 3 ITCs (2.3MW+2.3MW+1.2MW) and 1 circuit of 2 ITCs (2.3MW+2.3MW) each through medium voltage cables (10kV). These aluminum medium voltage cables will be preferably installed under duct through several trenches up to the Connection Center (CC). The design criteria to do the cable calculations will be that the maximum drop voltage in LV are 2% in DC side and 1% AC side.

From the switchgears the PV plant energy generated will be transported by separate circuits by a new overhead power line of 10kV to Ashnak substation about 5km north-east of the site.

- Connection Center contains following MV switchgears:
 - 2 Line switchgears, that correspond with the 2 connection circuits.
 - 2 PV production measurement switchgear.
 - 2 Evacuation switchgear.
 - 1 Coupling switchgear.
 - 1 Auxiliary Services Protection Switchgear.

The CC will be equipped with certified and homologated measurement system connected to the MV switchgears to get a measurement of the net energy.

From the CC an auxiliary power transformer will supply the necessary energy to devices (Aux. Services, lighting, power suppliers, etc.) of the Control Center used to control the operation of PV plant and Warehouse used to store maintenance elements. The consumption of the auxiliary services of the photovoltaic plant will be upstream of the general PV production to discriminate incoming and outgoing power.

Due to the PV plant location, the design of main equipment shall take into account the altitude of the site above sea level and it is foreseen that snow precipitations occur. The effect of snow is complicated and depends on several climate factors such as daily snowfall, snow depth, wind, temperature, temperature cycles, and irradiance. So the climate plays a role in system design (tilt and module height), mounting structure specifications and operations and maintenance plans (snow cleaning). The snow cleaning has already been taken into account in the operation and maintenance assumptions.

Generally fixed tilted systems are employed on sites with high wind or snow loads. However, some tracker suppliers have developed new products adapted to those kinds of climates. High snow loads increase stress on structural members and components, so tracking systems require additional steel and other materials, driving up costs.



5 SOLAR RESOURCE ANALYSIS

In order to estimate the expected electric output of a PV plant, a Typical Meteorological Year (TMY) is needed. The objective of a TMY is to represent the long-term average meteorological conditions at a site. The TMY shall be based on as many years as possible (ideally up to 30 years of site-specific observations and measurements). This TMY, based on long term historical data, provides the expected behavior in the long term (20 years or more), which is approximately the expected lifetime of a PV plant.

Thus, the TMY shall meet the following requirements:

- Representative of the natural years in the location.
- Main meteorological parameters related to natural years.
- Extrapolable to future years.

The objective of the TMY is not reproducing typical meteorological parameters at a particular time in the future, but reproducing the trends of the main meteorological parameters over the short term (seasonal trends) and the long term (annual trends), respectively, at a given location.

Often, getting this TMY from ground measured data is not possible, since it depends on the weather station network available in a country or region. However, satellite data can provide the long-term data series, while ground-measurements provide more accurate data with highest time-resolution.

Most of the inherent modeling uncertainty is tied up to the choice of the weather data file, thus the importance of the consistency in the meteorological data.

The solar radiation is a meteorological variable measured only in few stations and during short and, on most occasions, discontinuous periods of time. Solar radiation estimation from satellite images is currently the most suitable approach. It supplies the best information on the spatial distribution of the solar radiation and it is a methodology clearly accepted by the scientific community and with a high degree of maturity.

AFA has received from Client, TMY generated by an external company for each site for the use in the preliminary energy yield assessment. The following table shows TMY monthly values for this site:



Table 1 - TMY monthly values

	GHI (kWh/m ²)	TEMP. (°C)
January	50.5	-6.72
February	71.4	-5.38
March	149.5	0.03
April	172.0	6.37
May	204.4	11.16
June	261.3	17.42
July	260.1	20.81
August	233.7	20.25
September	187.2	15.30
October	134.4	7.58
November	85.2	0.29
December	59.4	-5.93
YEAR	1869.1	6.83

Figure 2 – TMY monthly values

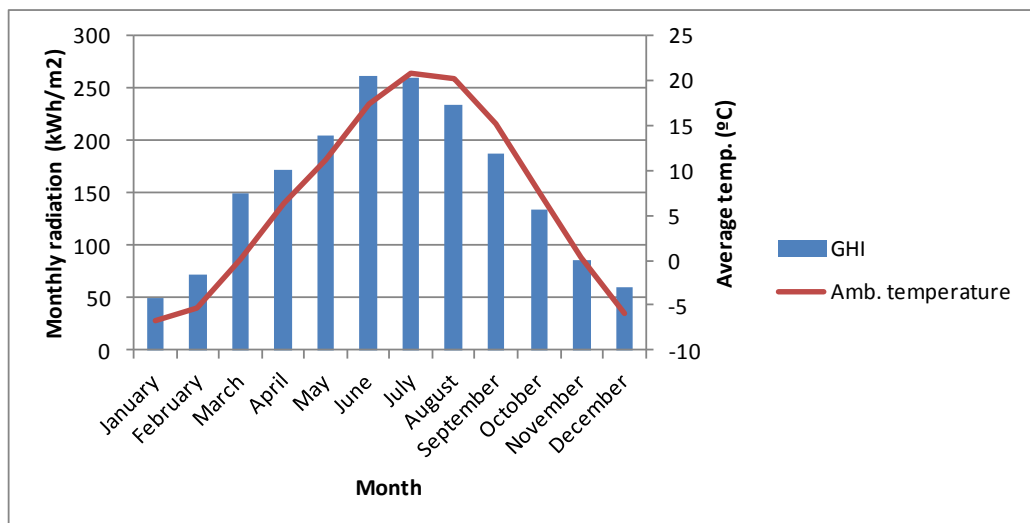



6 ENERGY YIELD ASSESSMENT

6.1 Model inputs and assumptions

To undertake the energy yield assessment, AFA has used PVSyst v6.43. PVSyst is a PV simulation tool developed initially at the University of Geneva, Switzerland. PVSyst is one of the most complex PV performance and financial model design tools in the industry. It was one of the first commercially available PV design packages; the newest versions are capable of precise output design of utility scale projects.

An annual performance analysis has been developed, to outline the impact of the most significant parameters which would affect the performance of the plant and the energy yield.

The following table outlines the main assumptions used by AFA.

Table 2 – Model assumptions

ITEM	VALUE	COMMENT
Orientation	South	Azimuth 0°
Mounting system	Fix structure	
Ground albedo	0.2	Ground reflectance
Module	JKM320PP-72	Jinko Solar 320 Wp
# modules	38988	
Inverter	Ingecon Sun 1165TL B420	Ingeteam 1164 kW at 30°C
# inverters	9	
Far shading/horizon losses	0.3%	Based on horizon profile from surrounding mountains in N-W side
Shading losses	2.2%	Mutual shading between rows based on structure design: 28° tilt and 7 m pitch between rows
IAM losses	2.1%	PVsyst calculation for the Project site location
Soiling losses	2.0%	Assumed
Irradiance losses	0.2%	Low irradiance losses
Temperature losses	4.5%	PVsyst calculation based on the meteorological data for the chosen location and the selected PV module technology
Module quality losses	-0.8% (gain)	0/+5W positive tolerance of modules
LID losses	1.0%	The light-induced degradation (LID) has been assumed based on available test data for polycrystalline modules currently on the market



ITEM	VALUE	COMMENT
Mismatching losses	1.0%	Losses due to modules different electrical parameters
Electrical DC losses	1.5% at STC	1.2% of energy loss
Inverter losses	1.50%	PVsyst calculation based on the module's and inverter's characteristics, sizing of the inverters, and the environmental conditions
Inverter clipping losses	2.20%	Overpower losses
Auxiliary losses	0.50%	Energy loss
Electrical AC losses	3.9% at STC	2.5% of energy loss
Transformer LV/MV losses	1.20%	Assumed: iron losses and load losses
Plant availability	99%	This value is assumed based on project experience

The energy value includes also evacuation line losses up to interconnection point.

6.2 Glossary of terms

GlobHor: Total irradiance on a horizontal surface, as read from the meteorological data file

TAmb: Ambient temperature, as read from the meteorological data file

GlobInc: Irradiance corrected for the array orientation

GlobEff: Irradiance corrected for the array orientation, shading objects, and incidence angle (reflection)

EArray: DC energy at the inverter input

EOutInv: Energy at the inverter output

EffArrR: Efficiency of the array ($E_{Array} / \text{rough area of system}$)

EffSysR: Efficiency of the system ($E_{OutInv} / \text{rough area of system}$)

Horizontal global irradiation: Amount of sun at a horizontal surface at the array's location.

Global incident in coll. Plane: Correction to irradiation to account for additional light reaching the modules due to module orientation (tilt and azimuth, or tracking with backtracking if applicable).

Horizon shading Factor on global: Correction to irradiation to account for less light reaching the array due to horizon objects (i.e. mountains).

Near Shading Factor on global: Correction to irradiation to account for less light reaching the modules due to shading by nearby objects (e.g. other rows of modules).

IAM factor on global: Correction to irradiation to account for less light reaching the modules due to incidence angle effects.

Effective irradiance on collectors: Total irradiation reaching the cells, accounting for all irradiation losses and enhancements.



PV conversion: Module efficiency at standard test conditions (STC). STC is defined as irradiance levels of 1000 W/m², module temperatures of 25°C, and AM 1.5 spectral distributions. The efficiency shown here reflects the output of the PVSYST module model rather than the specification sheet quoted value.

PV loss due to irradiance level: Losses due to (typically) reduced module efficiency at light levels below 1000 W/m². This quantity represents the annual average impact of this irradiance dependent effect.

PV loss due to temperature: Losses due to reduced module efficiency at temperatures above 25°C. For operation in cold environments, this may be a gain relative to STC.

Array Soiling loss: Annual losses due to snow and dirt buildup preventing some light from reaching the active layers of the modules.

Module quality loss: A directly applied “across-the-board” loss used to account for lot average power output falling short of nameplate rating. BEW often applies other “across-the-board” losses here such as transformer core losses.

Module array mismatch loss: Losses due to the combination of series current and parallel voltage mismatch can be estimated analytically via PVSYST as long as the production tolerance, nature of the distribution, and number of series and parallel strings is known.

Spectral correction for amorphous: A correction to account for amorphous modules different absorption characteristics from those of crystalline silicon modules.

Ohmic wiring loss: Given a value for ohmic loss at STC, PVSYST calculates the annual loss, correcting for deviations from STC.

Array virtual energy at MPP: DC energy at the maximum power point (MPP) after all the losses listed above have been taken into account.

Inverter loss during operation (efficiency): Inverter losses due to its efficiency curve.

Inverter Loss over nominal inv. Power: Inverter losses due to AC power output limitation.

Inverter Loss due to power threshold: Inverter losses due to array output below the inverter lower limit. Inverters typically fall back to a low-power standby state at night when the input power falls below this level. If this level is too high, a significant amount of available power may not be converted. This lost opportunity is counted as a loss due to power threshold.

Inverter Loss over nominal inv. Voltage: Inverter losses due to array voltage higher than inverter upper voltage limit for maximum power tracking.

Inverter Loss due to voltage threshold: Inverter losses due to array voltage below the inverter lower limit. To transition from nighttime standby to daytime operation, the inverter turns on when the (open circuit) array voltage exceeds a threshold. If this level is too high, a significant amount of energy may not be converted. This lost opportunity is counted as a loss due to voltage threshold.

Available Energy at Inverter Output: Energy at inverter output after all losses listed above are taken into account.



6.3 Performance results

ARIES has performed an analysis of the impact of the most significant parameters which would affect the performance of the plant and the energy generation.

The results of the performance analysis are as follows:

Table 3 – Performance results

ITEM	VALUE
Energy generated (MWh/year)*	21596
Energy generated (MWh/year)**	21380
Specific energy (kWh/kWp/year)*	1731
Specific energy (kWh/kWp/year)**	1714
Performance Ratio	80.3%

* PVSYST simulation is performed taking into account 100% availability.

** Energy values are also provided assuming 99% plant availability.

7 INSTALLATION DESCRIPTION

7.1 Generating System

The generating system consists of a group of PV modules connected in series and in parallel with each other to achieve an optimal level of output voltage and current ranges compatible with the input of inverter model selected.

The photovoltaic system consists of:

- 4 blocks of 2.3MW
- 1 blocks of 1.2MW.

Each 2.3MW block has 456 (14 combiner boxes x 30 parallel series per combiner box plus 2 combiner boxes x 18 parallel series) series in parallel. Each serie is composed by 19 PV panels connected in series.



Table 4 – Generating System 2.3 MW. Main Characteristics

Description	Value	Units
Number of PV modules in series	19	panels
Number of Series per ITC(General Block) of 2,3 MW	456	series
Number of Modules per ITC(General Block) of 2,3 MW	8664	modules
Number of ITC(General Block) in PV Plant	4	ITC´s

The 1.2MW block has 228 (7combiner boxes x 30 parallel series per combiner box plus 1 combiner boxes x 18 parallel series) series in parallel. Each serie is composed by 19 PV panels connected in series.

Table 5 – Generating System 1.2 MW. Main Characteristics

Description	Value	Units
Number of PV modules in series	19	panels
Number of Series per ITC(General Block) of 1.2 MW	228	series
Number of Modules per ITC(General Block) of 1.2 MW	4332	modules
Number of ITC(General Block) in PV Plant	1	ITC´s

The parallel connection of the PV modules series will take place in direct current combiner boxes distributed by the solar field. In this combiner box, will be installed protection (fuses and surge arrester) and switch-disconnector of series that will allow maintenance and switching operations.

7.2 Modules

The installation of 10.47MW (12.47MWp) consists of 38988 modules of 320Wp power with the following characteristics:

Table 6 – PV Module. Main Characteristics

Description	Value	Units
Model	JKM320P	
Technology	Polycrystalline	
Max-Power	320	Pm(Wp)
Max-Power Voltage	37.4	Vm(V)
Max-Power Current	8.56	Im(A)
Open-Circuit Voltage	46.4	Voc(V)
Short-Circuit Current	9.05	Isc(A)
Coef T ^a Voc	-0.31	%/°C
Coef T ^a Isc	0.06	%/°C



Description	Value	Units
Maximum System Voltage	DC1000	V
Length	1.956	m
Width	0.992	m
High	0.04	m
Weight	26.5	kg

7.3 Inverters

Each inverter will receive the DC power generated by its subsystems and transform it into AC power, to evacuate it to the grid. To generate the 10.47MW (12.47MWp) there will be a total of 9 inverters 1164kW of power in the PV plant.

This inverter selection is done by the possibility that receive set-points signals to compensate reactive power, voltage ride-through.... etc. The inverter will comply with the applicable standards.

Table 7 – 1164 kW Solar Inverter. Main Characteristics

Description	Value	Units
Model	INGECON SUN 1165TL B420 Outdoor	
Max. DC power	1513.2	kW
Max. DC voltage	1050	Vdc
MPP voltage range	610 - 820	Vdc
Max. DC current	2000	A
Max. AC power at 35°C	1163.9	kVA
Max. AC power at 50°C	1071	kVA
AC output voltage	420	Vac
AC grid frequency	50-60	Hz
Dimensions	2820/2200/920	mm
Weight	1920	kg
Protection rating	IP 54	
Power factor (cos φ)	± 1 adjustable	
Operating temperature range	-20 to +65	° C
CEC efficiency	98.70	%
Max. Altitude above sea level	3000	m



7.4 Combiner boxes or junction boxes

The combiner boxes or junction boxes (JB) are used to group the number of strings to one output and to protect the strings with fuses. The JB will be prepared up to 30 strings.

The JB will be equipped with different devices:

- Fuses: to protect the strings against the electrical faults
- Switch-disconnector to do an electrical separation and disconnect all the strings that the JB joins.
- Overvoltage devices (electrical discharger) to protect it against overvoltage faults.
- Ground terminal and ground connection: to protect the device against electrical risks.

7.5 Generation Medium voltage transformers

In PV plant will be installed 4 medium voltage transformers of 2.3MVA and 1 medium voltage transformer of 1.2MVA, one by each ITC.

The transformers will be employed to step up the low voltage output from inverters to the internal medium voltage of the plant that is 10kV. The 2.3MW ITC blocks transformers will have double secondary windings to optimize the interconnection with the two inverters and the 1.2MW ITC block will have only a single winding to connect its inverter. The transformers will be with very low losses (1%).

There will be placed in prefabricated galvanized steel buildings (container-type) with inverters and auxiliary power transformers.

Table 8 – 2.3MW Block. Medium voltage transformers. Main characteristics

Description	Value	Units
Transformer Rated Power	2330	kVA
Phases	3 Phase	
Nominal Frequency	50	Hz
High Voltage	10000	V
Low Voltage	420	V

Table 9 – 1.2MW Block. Medium voltage transformers. Main characteristics

Description	Value	Units
Transformer Rated Power	1200	kVA
Phases	3 Phase	
Nominal Frequency	50	Hz
High Voltage	10000	V
Low Voltage	420	V

NOTE: Due to the PV plant location, the design of generation medium voltage transformers shall take into account the altitude of the site above sea level.



7.6 Auxiliary Medium voltage transformers

In PV plant will be installed 5 low voltage power transformers (10kVA) for the auxiliary services of ITCs and 1 medium voltage power transformer (50kVA) for the auxiliary services of Control Center and Warehouse.

The auxiliary low voltage power transformers will be located inside of ITCs and it will be employed to step down the output voltage of inverters (420V) to supply the necessary energy for the auxiliary services of each ITC.

Table 10 – 10kVA Auxiliary low voltage power transformers. Main characteristics

Description	Value	Units
Transformer Rated Power	10	kVA
Phases	3 Phase	
Nominal Frequency	50	Hz
High Voltage	420	V
Low Voltage	400	V

The auxiliary medium voltage power transformer will be located inside of Connection Center and it will be employed to step down medium voltage of the grid connection (10kV) to low voltage (400V) of auxiliary services electrical consumptions of Control Center and Warehouse.

Table 11 – 50kVA Auxiliary medium voltage power transformers. Main characteristics

Description	Value	Units
Transformer Rated Power	50	kVA
Phases	3 Phase	
Nominal Frequency	50	Hz
High Voltage	10000	V
Low Voltage	400	V

NOTE: Due to the PV plant location, the design of auxiliary power transformers shall take into account the altitude of the site above sea level.

7.7 Low voltage Cable

7.7.1 DC Cable 1

This cable will be employed to connect the module with combiner boxes or junction boxes.

7.7.1.1 Constructive characteristics

Cable: Cable for PV system, single core insulated, with additional coating, type P-Sun 2.0.

Isolated conductor: Isolated conductor without cover.

Insulation types:

- Thermostable: XLPE.
- Acronym:
 - R: insulation XLPE (cross-linked polyethylene).

The specified insulation has different temperatures:

(Max.Operating Temp – Max.Overload Temp – Max.Short-circuit Temp (max 5 s.))

- XLPE (90 - 120 – 250)



Each pole shall be identified during the laying operation using different colors of a PVC tape around the cable, both in the beginning and end of lying, as in the joints.

All cables shall be marked on the outer cover, indicating every meter the length of each roll referred to the beginning of the coil wire.

All cable shall have printed each meter with the data below, in a legible and indelible way. It must be printed on the outer cover: manufacture identification, cable description, year manufacture identification (2 last digits), certification mark, number of conductors and their section, insulation voltage, and length mark.

7.7.1.2 Particular characteristics.

- Type: P-Sun 2.0
- Conductor: stranded electrolytic copper, tinned, and compressed.
- Flexibility: class 5. Flexible to handle easily.
- Rated voltage and the basic isolation level (BIL) will prepare for 0.6/1 kV.
- Insulation: XLPE.
- Sheath: EVA 120°C (Ethylene-Vinylacetat-Copolyme).

Behavior in case of fire

- Halogen-free.
- Low smoke emission.
- Corrosivity according to DIN EN 502641.

7.7.2 DC Cable 2

This cable will be employed to connect combiner boxes or junction boxes with PV inverter.

7.7.2.1 Constructive characteristics

Cable: Single-core isolated conductor with additional sheath.

Isolated conductor: Isolated conductor without cover.

Types of insulation: Thermostable: XLPE.

Depending on the type of insulation, the differences are:

(Max. Service Temp – Max overload Temp. – Max. Shortcircuit Temp. (5 s. Max.)

- XLPE (90 - 105 – 250)

In single core cables for each phase is identified by a tape laying of PVC in different colors around the cable, both the beginning and end of lying as in the joints and manholes by encoding suitable.

All cables have a marking on the outer cover, which indicates, meter by meter, the length of each pull cable mentioned at the beginning of the coil.

The coils are marked as indicated in the Supply Contract; the number identifying the coil will be appointed following an encoding that is defined later during the order placement.

All cable shall have printed each meter with the data below, in a legible and indelible way. It must be printed on the outer cover: manufacture identification, cable description, year manufacture identification (2 last digits), certification mark, number of conductors and their section, insulation voltage, and length mark.



7.7.2.2 Particular characteristics.

- Designation: Al XZ1.
- Conductor: Class B concentric compact aluminum.
- Flexibility: class 2.
- Isolation voltage: 0.6/1 kV.
- Insulation: XLPE.
- Screen: No.
- Cover: Special mix zero halogen type DMO1.

Characteristics against the fire:

- No flame propagation.
- Low smoke emission.

7.7.3 AC Cables

This cable will be employed to feed all the auxiliary services.

7.7.3.1 Constructive characteristics

Cable: Isolated conductor with additional sheath, both single-core and multi-core.

Isolated conductor: Isolated conductor without cover.

Types of insulation: Thermostable: XLPE.

Depending on the type of insulation, the differences are:

(Max. Service Temp – Max overload Temp. – Max. Shortcircuit Temp. (5 s. Max.)

- XLPE (90 - 105 – 250)

In single core cables for each phase is identified by a tape laying of PVC in different colors around the cable, both the beginning and end of lying as in the joints and manholes by encoding suitable for three-core cables.

All cables have a marking on the outer cover, which indicates, meter by meter, the length of each pull cable mentioned at the beginning of the coil.

The coils are marked as indicated in the Supply Contract; the number identifying the coil will be appointed following an encoding that is defined later during the order placement.

All cable shall have printed each meter with the data below, in a legible and indelible way. It must be printed on the outer cover: manufacture identification, cable description, year manufacture identification (2 last digits), certification mark, number of conductors and their section, insulation voltage, and length mark.

7.7.3.2 Particular characteristics.

- Designation: RV-K.
- Conductor: stranded electrolytic copper, tinned, and compressed
- Flexibility: class 5. Flexible to handle easily.
- Isolation voltage: 0.6/1 kV.
- Insulation: XLPE.
- Screen: No.



- Cover: Polyvinyl chloride (PVC), type DMV-18.

Characteristics against the fire:

- No flame propagation.
- Low smoke emission.

7.8 MV AC Cable

7.8.1 MV cables for PV Plant

- Conductor: Compact circular stranded compacted aluminum.
- Conductor screen: Extruded semi-conducting compound bonded to the insulation and applied in the same operation as the insulation.
- Insulation: Extruded cross-linked polyethylene (XLPE) suitable for operation at a conductor temperature of 90°.
- Insulation screen: Extruded semi-conducting compound applied in the same operation as the insulation. Cold strippable screens are supplied as standard but fully bonded screens may be provided if specified.
- Metallic screen: Copper tapes applied overlapped to provide an earth fault current path.
- Tape Separator.
- Oversheath: Extruded black polyvinyl chloride (PVC) or Low Smoke Zero Halogen (LSOH) compound is supplied as standard. Alternative materials may be provided if specified e.g. medium density polyethylene (MDPE).

In single core cables for each phase is identified by a tape laying of PVC in different colors around the cable, both the beginning and end of lying as in the joints and manholes by encoding suitable for three-core cables.

All cables have a marking on the outer cover, which indicates, meter by meter, the length of each pull cable mentioned at the beginning of the coil.

The coils are marked as indicated in the Supply Contract; the number identifying the coil will be appointed following an encoding that is defined later during the order placement.

All cables will cover printed indelibly marked each meter at least the following information:

- Identification of the manufacturer.
- Name of the cable.
- Identification of the manufacturing year.
- Mark of the certification.
- Number and cross section of the cables.

7.9 Switchgears

There will be two different types of switchgears as specified:

7.9.1 ITC Switchgears

There will be these types of switchgears: transformer protection and incoming and outgoing switchgear. The main characteristics are:

- Model: SM6 (Schneider or similar).



- Load break switch: 3 positions (closed, opened and ground connected).
- Rated maximum voltage: 24 kV.
- Rated impulse BIL: 125 kV.
- Insulation (Ud) 50/60 Hz, 1 min (kV rms): 50
- Isolation (Ud) 50/60 Hz, 1 min (kV rms): 60
- Insulation Up 1.2/50 μ s (kV peak): 125
- Isolation Up 1.2/50 μ s (kV peak): 145
- Rated current: 400 A.
- Gas insulated: SF6
- Nominal frequency: 50 Hz

NOTE: Due to the PV plant location, the design of switchgears shall take into account the altitude of the site above sea level.

7.9.2 CC Switchgears

There will be these types of switchgears: transformer protection, measurement, incoming and outgoing switchgear. The main characteristics are:

- Model: SM6 (Schneider or similar).
- Load break switch: 3 positions (closed, opened and ground connected).
- Rated maximum voltage: 24 kV.
- Rated impulse BIL: 125 kV.
- Insulation (Ud) 50/60 Hz, 1 min (kV rms): 50
- Isolation (Ud) 50/60 Hz, 1 min (kV rms): 60
- Insulation Up 1.2/50 μ s (kV peak): 125
- Isolation Up 1.2/50 μ s (kV peak): 145
- Rated current: 630 A.
- Gas insulated: SF6
- Nominal frequency: 50 Hz

NOTE: Due to the PV plant location, the design of switchgears shall take into account the altitude of the site above sea level.

7.10 Grounding General Description

A grounding system should be installed in a manner that will limit the effect of ground potential gradients to such voltage and current levels that will not endanger the safety of people or equipment under normal and fault conditions. The system should also ensure continuity of service.

The system of ground electrodes will have the form of a grid of horizontally buried conductors, supplemented by a number of vertical ground rods connected to the grid. Horizontal (grid) conductors are most effective in reducing the danger of high step and touch voltages on the earth's surface



Rods penetrating the lower resistivity soil are far more effective in dissipating fault currents whenever a two-layer or multilayer soil will be encountered and the upper soil layer has higher resistivity than the lower layers.

7.10.1 Grounding Conductors

Grounding conductors shall be stranded soft drawn annealed copper material or equivalent.

7.10.2 Grounding Rods

Ground rods shall be Copperweld material or equivalent.

As a general conception grounding system shall be such that when connected to other on site grounding networks, the electrical resistance between networks shall be 0.5Ω or less.

7.11 Auxiliary Services

The general auxiliary services of the PV plant will be feed from auxiliary medium voltage power transformer located inside of Connection Center. This auxiliary transformer will step down medium voltage of the grid connection to low voltage and it will be interconnected with the auxiliary low voltage panel board which will supply the auxiliary services of Control Center and Warehouse.

The general auxiliary services will be the following:

- Lighting
- Sockets
- Air-conditioning system
- Fire protections
- Security system
- Operation and control system
- Warehouse electrical consumption

On the other hand, the ITCs will have electrical consumption which will be feed from an auxiliary low voltage power transformer located inside of each ITC and it will step down the output voltage of inverters to low voltage of following auxiliary services:

- Inverter power supply
- Cooling fans power supply
- Lighting
- Sockets
- Smoke detectors
- MV Switchgears power supply
- Thermal protections
- Monitoring and Control equipment

7.12 Essential Services

To ensure proper operation of PV plant it is necessary the power supply to part of auxiliary services (essential services) shown in section above in case of grid failure.



The essential services of Control Center and Warehouse will be fed by an Emergency Diesel Generator in case of grid failure which will provide necessary low voltage power supply at least to following services:

- Fire Protections
- Security system
- Operation and control system
- Safe lighting
- Safe sockets

The independent fuel storage capacity shall be sufficient to maintain supplies to the PV plant for minimum 12 hours.

In addition, part of these essential services are considered critical services and it will be fed by an uninterruptible power supply (UPS) located in Electrical Room of Control Center in case of Emergency Diesel Generator failure. The essential services connected to UPS are:

- Operation and control system

The essential services of each Inverter Transformer Centers (ITC) will be fed by an uninterruptible power supply (UPS) located in each one and are the following:

- Inverter power supply
- Thermal protections
- Monitoring and Control equipment
- MV Switchgears power supply

NOTE: Annex "14.5 PEF2827-049-Dashtadem 1-BOM" shows an estimate bill of materials and main equipment required for this PV plant.

8 EVACUATION POWER LINE

An overhead power transmission line of 10 kV with total length of about 5.5 km should be constructed from substation of Dashtadem PV plant to Ashnak substation. Altitude of the Dashtadem PV plant substation and Ashnak substation are 1394 m.a.s.l. and 1578 m.a.s.l.

The overhead lines of 10 kV include the following structural elements: conductors, supports (poles), insulators, overhead line hardware (fittings) for fastening of wires on insulators and insulators on supports.

Design, construction and commissioning of overhead lines are regulated by Electric Installation Code and Operational Regulation Code as well as Standards and Building Codes effective in the Republic of Armenia.

The information provided in this document is indicative. The Investor and his contractor shall remain solely responsible for the design.



Figure 3 – Scheme of 10 kV overhead lines

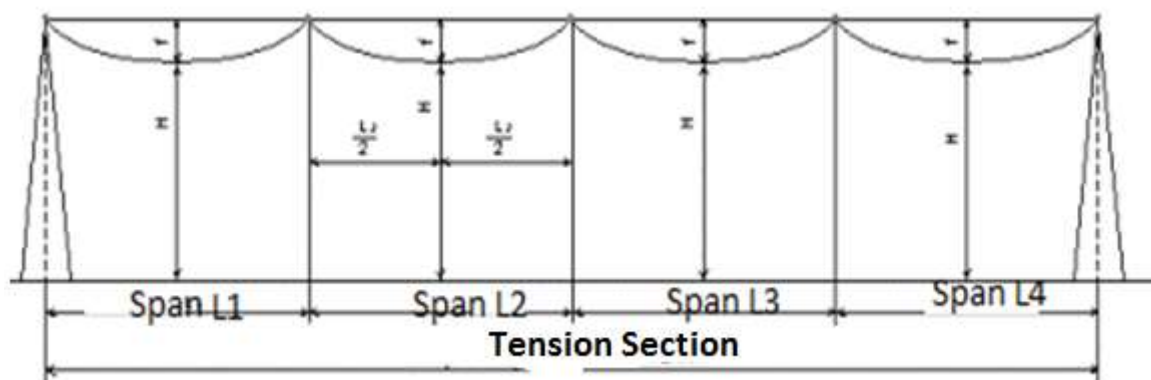

8.1 Transmission line main characteristics

	Value	Unit
Nominal Voltage U_n	10	kV
Highest System Voltage U_{max}	12	kV
Design Voltage U_m	12	kV
Frequency	50	Hz
Industrial frequency withstand voltage (1 min)	230	kV
System Configuration	Single Circuit	
Number of Conductor per phase	2	
Number of earthshield wire	1	

8.2 General description of 10kV line elements

The 10 kV lines consist of following elements.

8.2.1 Supports

The purpose of a transmission structure is to keep the high voltage phase conductors away from their surroundings and from each other, in this line they are wooden or concrete structures although this depends on the final design and calculus.

Wooden poles are easy to manufacture, cheap, but short-lived. Concrete supports are expensive, but more durable.

For 10 kV overhead lines the span between supports usually makes 100-150 m and the height of supports is about 10.5m.

The distance from the underground part of the overhead line support to underground sewer lines should be not less than 2 m.

The main gas and petroleum product pipelines must be routed beyond security zone of overhead line, which is 10 m for 10 kV overhead lines. This distance is measured from horizontal projections of edge conductors up to pipelines. In the cramped conditions it is allowed decrease of secure zone up to 5 m for overhead lines of up to 10 kV.



8.2.2 Types of supports

Depending on their duty within a transmission line, the following structure types are typically designed:

Intermediate supports are installed on the straight sections of the overhead line route. These supports normally should not take efforts along the overhead line.

Angle-suspension supports are installed where the direction of overhead line is changed. These supports normally take tension of the wires adjacent spans.

Dead-end supports are installed on the intersections with different structures, as well as changes of marks and wire sections. These supports must take difference of tension wires directed along the overhead line. Dead-end supports should have a rigid structure.

Terminal supports are located at the beginning and the end of overhead line as well as at cable inserts. They are type of dead-end supports.

Reinforced concrete intermediate supports are tangent structures with horizontal wires on pin insulators.

Figure 4 – Reinforced concrete intermediate supports for overhead lines of 10 kV

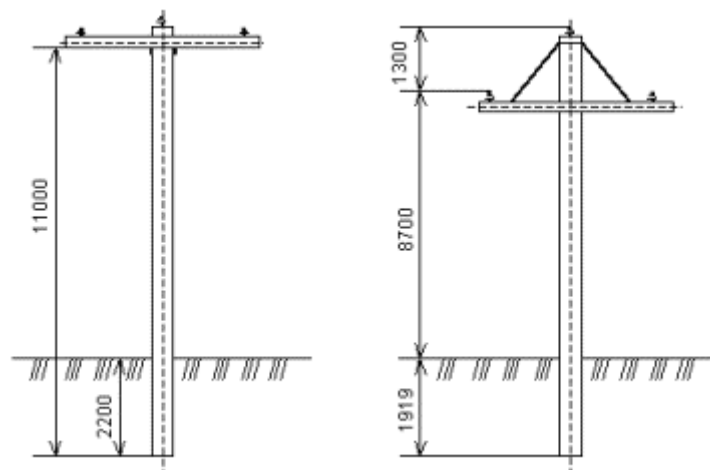

8.2.3 Conductors

Aluminum, steel reinforced aluminum and steel conductors are used for overhead lines.

The conductor in this project is a 185/29 mm² to minimize the power losses.

8.2.4 Insulators

Glass or porcelain pin insulators mounted on traverses are used for 10 kV overhead lines

8.2.5 Overhead line hardware (fittings)

The Overhead line hardware is a metal structures (traverse) on which insulators are mounted.

8.2.6 Earthing

To protect against lightning surges reinforced concrete supports of overhead lines with voltage up to 10 kV should be grounded both in populated and unpopulated areas.



Earthing system of an overhead line is a vertical grounding rod made of angle steel or another suitable material.

9 SURVEILLANCE SYSTEM

The first security system will be a perimeter fence though its description is developed later in the civil works section. This surveillance system of the plant will be based on a video detection system

This system is continuously monitoring and processing video images in order to detect intrusions of people, vehicles and objects, and performing intruders tracking when a forbidden intrusion is detected.

When a non-allowed intrusion is detected, recording function is activated and alarms are generated and sent to the security office or Control Center.

This system is composed by fixed cameras, mobile cameras and automatic software for real time processing and analyzing images which detect models to determine when an intrusion is happening, avoiding false alarms and without permanent human participation.

This software permits several types of detection:

- One based on detection of object moving into a forbidden zone, or moving in a forbidden direction.
- Virtual line trespassed: the software allows defining several virtual lines per scene. If one of these lines is trespassed in a forbidden direction an alarm is activated.
- Object removal alarm: if an object is removed from its assigned place an alarm is activated.
- Unauthorized vehicles stop in a controlled zone
- Abandoned object: if an object is kept into an unauthorized zone for more than a predetermined period of time an alarm is triggered.

The role of mobile cameras is to track intruder movements when an alarm has been triggered and it is moving out of fixed camera scope.

The installation is scalable and allows future expansions if needed.

To implement the surveillance system, the following devices will be installed:

- Fixed cameras enabling video analysis and movement detection capabilities.
- Metallic posts installed on cement foundation where cameras are installed, with anti-sabotage system.
- Mobile camera to perform intruder movements tracking.
- Infrared illumination focuses.
- Surprising illumination and horns to be activated from the alarm center.
- Central surveillance monitoring center with operators HMI.
- High quality recording system.
- UPS with 2 hours capacity.
- Racks hosting electronic equipment in Control Center.
- Auxiliary devices to protect the system against adverse meteorological conditions or power deviation.
- Data loggers.



- Analyzers for image processing.

Fixed cameras are to be installed every 50m, following the schema shown below:

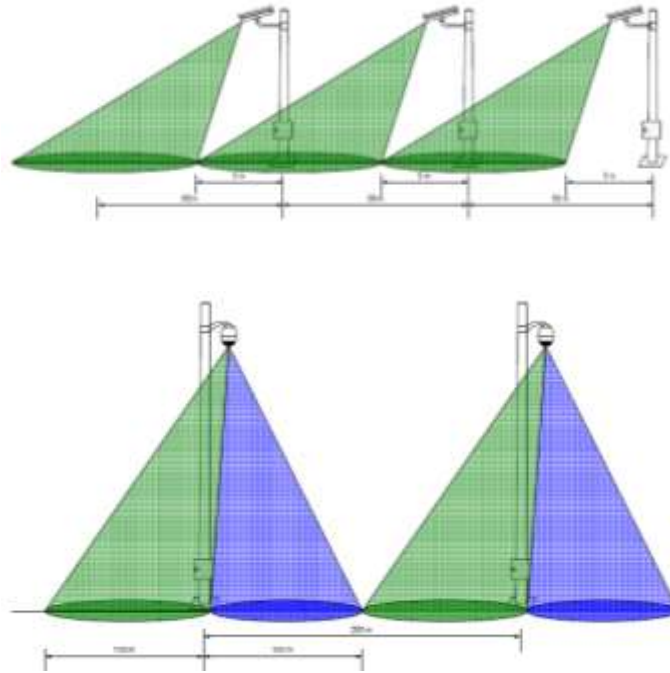

The system will send data allowing the system to be controlled either remotely or locally. The communication net shall be safe, redundant and highly reliable. In case of an internet node is not available, a radio or satellite link will be installed.

Figure 5 – Security Schema

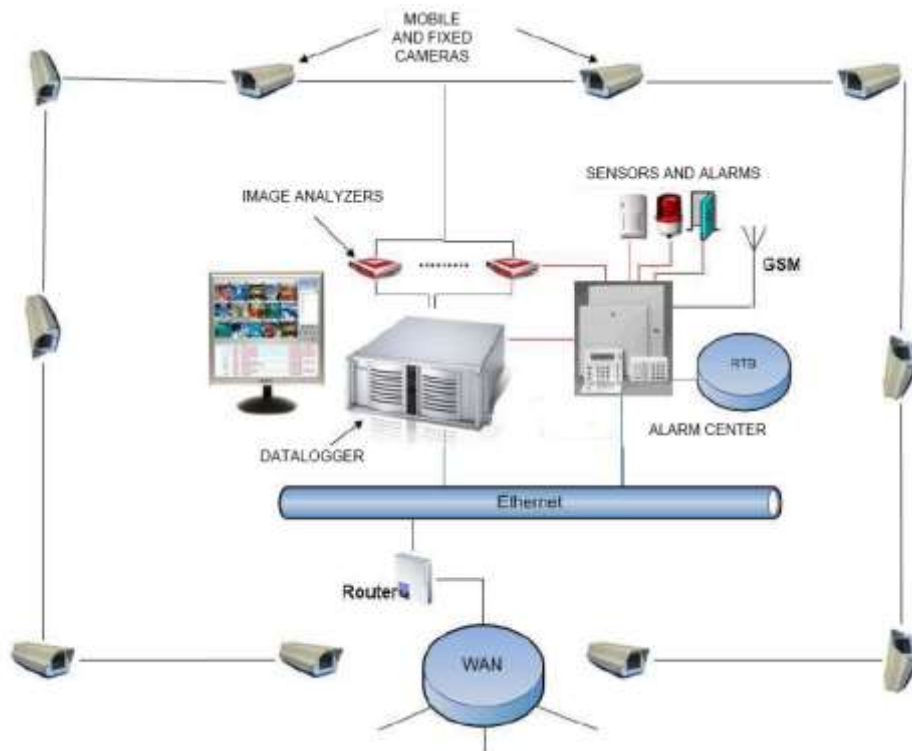



10 MONITORIZATION SYSTEM

It shall be designed in order to achieve a global and detailed view of the operation of the plant and a failure or deviation detection tool.

The data acquisition levels are:

- Junction boxes: measuring voltage and intensity in photovoltaic generators
- Inverters: input and output process variables at the inverter
- Meteorological station
- Measuring counters at the battery limit of the PV plant, in order to know the energy delivered to the electric company.

All these data are sent, by means of a fiber optic net, to the Control Center, where a SCADA application is installed. This SCADA will be continuously evaluating inverter values in order to supervise which are producing with poor performance and to allow corrective actuations.

10.1 Description

The following variables, among others, are monitored:

- Power delivered to the Grid, totalized by months, years or other time scope.
- Grid voltage, intensity and frequency.
- Total power of the plant: active and reactive.
- Current and voltage per phase.
- Delivered active energy.
- Daily energy.
- Performance ratio.
- Average performance of the plant and compared performance of each string.
- Irradiance, ambient temperature and other relevant meteorological variables.
- Inverter status, maximum power point, energy and power delivered alarms and diagnostics.
- Communication diagnostic and failures supervision.

All these data will be available at the Power Plant Control center as well as remotely using a web site.

The SCADA system shall perform monitored data storage and a daily local back-up copy. Also, an external back-up and data storage will be also done in order to enhance maintenance and availability of the plant.

The SCADA will have several means of data visualization: a general plant view with the most significant values which allow navigating to detailed faceplates for each inverter, string, or meteorological station. It also have available reports, trends and comparisons and alarms logs, in which pre-alarms, confirmed alarms and recognized alarms are stored and identified.

10.2 Equipment

- Meteorological station: includes measurement of temperature, atmospheric pressure, wind, humidity, rain, and solar irradiation sensors (pyranometers). Meteorological station will be mounted on tower of 6 m height.
- Counter for plant output.



- Grid analyzer, to measure voltage, current, frequency, harmonics, reactive power, impedance. Main purpose of this device is the analysis of the quality of the link plant grid.
- Data loggers.
- System of communications plant-client, it works with the protocols of communications supplied in meteorological station, grid analyzer, inverters, and with data provided from the points chosen by the client.
- Communications with the client, and with maintenance service. It can be through ADSL, 3G, and GSM. Apart from the system for the client, another communication system for grid manager will be installed. This will report the required measurements by the company, through modem, via ADSL, 3G, GSM. This communication system will allow grid manager remote control over every switch located at MV side of every transformer, in order to disconnect/reconnect them if necessary. Wiring of this will be made with optical fiber. Devices of both systems can be located in the cabin for point of connection, next to counter.
- Server based on PC, with redundant hard disc, DVD recorder, and monitor, mounted on rack.
- UPS with automatic reboot
- Windows operative system, SQL server and VNC tools.
- For O&M activities, a local operation workstation will be installed on site.
- Inside inverter building, the following equipment will be installed:
 - PLCs for local control
 - F.O switch
 - UPS
 - RS485-TCP/IP gateways



Figure 6 – Monitorization System Schema

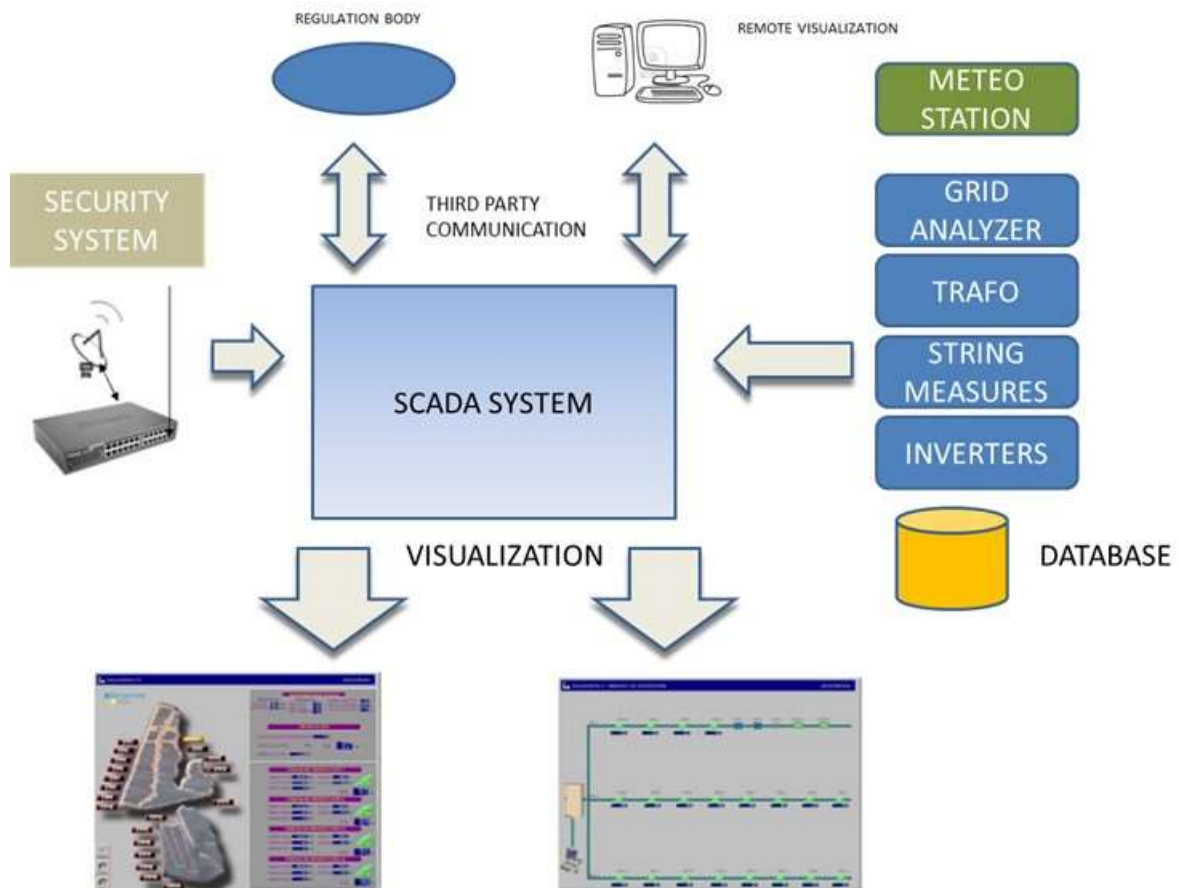

10.2.1 Meteorological station

Meteorological station shall allow the measurement of all type of meteorological variables, data treatment and storage, and provide versatility for communications, local and remote configuration and programming. Accordingly open communication protocol shall be provided.

Station will be specially designed for outdoors installation, in remote unattended areas

For data storage and internal data logger for 3 months data storage shall be included, external SD card shall be included also, at least 32 GB. All measured variables and instruments status signals shall be stored. Sampling time of data acquisition and storage shall be configurable by the user. Minimum 1 minute.

Meteorological station shall be design to operate with the following power inputs:

- External grid 220V 50Hz.
- Internal battery system charged by a solar panel dimensioned for 5 days autonomy.
- Meteorological station shall accept signal from instrument in the following type:
 - 0/4-20 mA current signal.
 - 0-24 VDC digital input or outputs.
 - Pulse counter.
 - Resistance and thermocouple signals.

At least following interfaces and communication protocols shall be supported:



- RS232
- RS485
- GSM/GPRS
- TCP/IP
- Modbus

The meteorological station receives information from the following instruments:

- Temperature:
 - Range -30/+70 °C
 - Accuracy 0.1°C
- Relative humidity
 - Range 0-100%
 - Accuracy +/-3%

Combined sensor for temperature and relative humidity is allowed.

- Rainfall:
 - Technology tilting cups or other state of the art accumulation technology
 - Collector area: 200 cm²
 - Accuracy: 5%
- Ambient pressure
 - Range 600-1100 mb
 - Accuracy +/- 0.3 mb
- Wind
 - Horizontal speed
 - Range 0-50 m/s
 - Accuracy 1 m/s
- Direction
 - Range 0°-360°.
 - Accuracy 2°
- Global radiation (piranometer)
 - ISO 9060 Classification: First class (WMO Good Quality)
 - Range: 0-2000W/m²
 - Spectral response : 305 ~ 2800nm
 - Response time : approx. 5 sec. (95% response)
 - Field-of-view : 2π steradian
 - Sensitivity : approx. 7-14μV/W·m²



11 CIVIL WORKS DESCRIPTION

11.1 Earth movements

The total area occupied by 12.5MWP PV plant is approximately 235378 m², with the distribution shown in the following figure:

Figure 7 – Occupied area

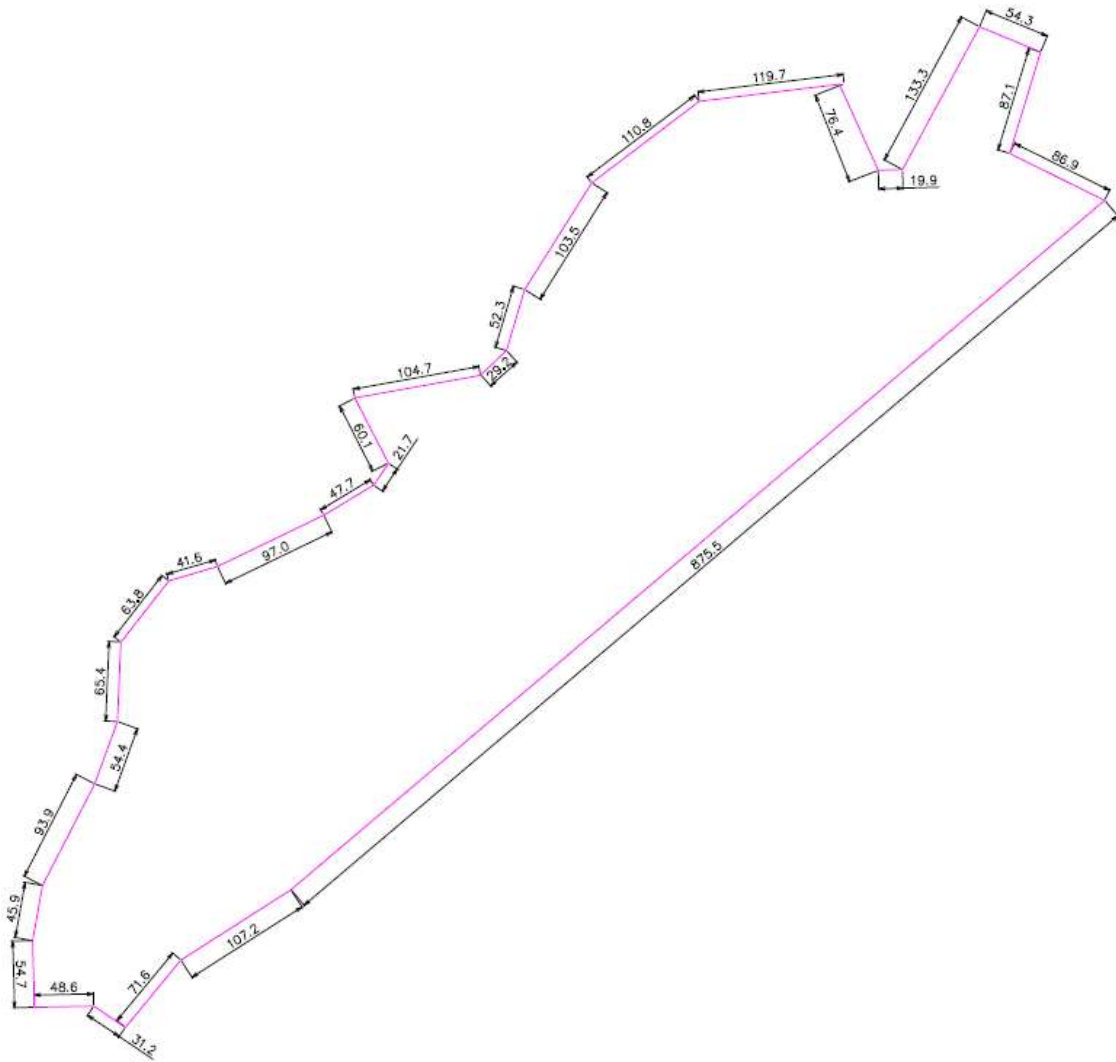

Alignment and slope allowable in the terrain shall fulfill the requirements of the photovoltaic provider.

The area shall be free of obstacles and it will comply with all the structure installation requirements, with adequate dimensions to allow movement of vehicles employed in the civil works.

If it is necessary, it will be cleared the vegetable layer. If the land will not be enough strong, there will be prepared an adequately compacted base.



The terrain used for the construction will comply with geotechnical report conditions and should be moisture-conditioned and placed and compacted in accordance with its recommendations.

11.2 Roads

11.2.1 Perimeter road

A perimeter road will be implemented joining the internal roads in the outline of the General Blocks to improve the mobility.

11.2.2 Internal road

The purpose of the internal roads is to allow access to various facilities in the solar plant, during construction, operation and maintenance on a safe way. The internal road connects the perimeter road in the middle of the site.

Considering the hydrology study and drainage system designed in the plant will assess the design of the roads drainage.

11.2.3 Parking area

A parking with capacity of at least 15 vehicles will be necessary. This parking is available in the vicinity Control Center.

The roads will have the appropriate transversal slope for drainage to reduce pending and infiltration of water into the pavement and sub-grade materials. The construction of perimeter swales, edge drains, curbs and gutters, or combination of these drainage devices is recommended to reduce the adverse effects of surface water runoff. The design of the alignment of each road will be carried out adequately to let the vehicles to pass over these roads under safety and comfortable conditions.

The sizing of the type section will be done taking into account the heavy traffic category (number of vehicles per day) and types of soils of the embankment, ensuring the correct transmission of loads during the useful life of the plant.

11.3 Buildings

The following buildings are considered:

11.3.1 Control Center

Prefabricated galvanized steel building (container blocks-type). It will contain an occupation of 12.5m*6m (75m²) approximately, sharing inside a control room, toilet and dressing room, kitchenette and electrical room. It will be available in the vicinity a parking.

11.3.2 Warehouse

Prefabricated galvanized steel building (container blocks-type). It will contain an occupation of 12.5m*6m (75m²) approximately.

11.3.3 Inverter transformer center (ITC)

Prefabricated galvanized steel building (container-type) with approximately dimensions 6 x 2.5 x 2.9 m (or similar) with one or two inverters, one medium power transformer, one auxiliary power transformer, and all auxiliary elements to lighting, auxiliary power supply, ventilation, security and fire protection.



Figure 8 – ITC Building

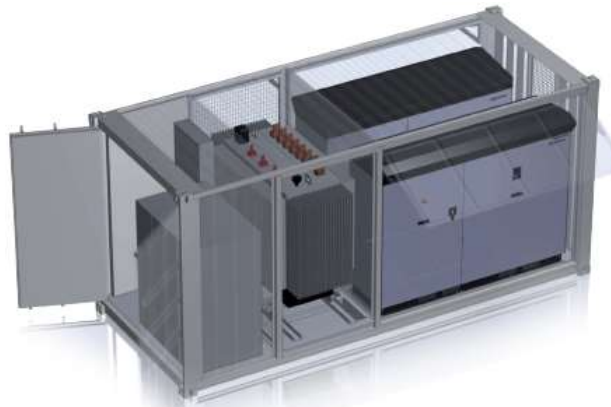

11.3.4 Connection center (CC)

There will be a prefabricated concrete building with approximately dimensions 9.6 x 2.6 x 3.6 m (or similar) with auxiliary medium voltage power transformer, medium voltage switchgears and all auxiliary elements to lighting, auxiliary power supply, ventilation, security and fire protection.

Figure 9 – CC Building



11.4 Structure of photovoltaic modules

According to photovoltaic structures providers the supporting structure (columns, tubes, bars and levers) of photovoltaic modules normally is hot-dip galvanized steel (according to EN ISO 1461). All the elements will be bolted. Welding, drilling or cutting is not necessary on site.

Main structure will be formed by foundation posts and rails, both produced by hot-dip galvanized steel profiles. Two foundation posts will form one support unit. This allows wider support distances and bigger module areas. The PV modules will be horizontally assembly on the rails with the appropriate fastening system to withstand the loads due to the weight of the PV panels and to those generated by weather conditions.

It may ensure an adequate durability strategy and will be considered all possible mechanisms of degradation, identifying these, by the exposure class that defines the aggressiveness of site and thus establishing the most appropriate method of protection, throughout the useful life of the solar plant.

Therefore, the design of a metal structure shall include the measures necessary so that the structure has the useful service life, as a function of the environmental and soil aggressiveness conditions to which it may be subjected. A durability strategy shall therefore be included. Also the metal structures should be designed to requirements of stability and structural analysis.

The following figures describe the supporting structures:



Figure 10 – PV structure Lay-out

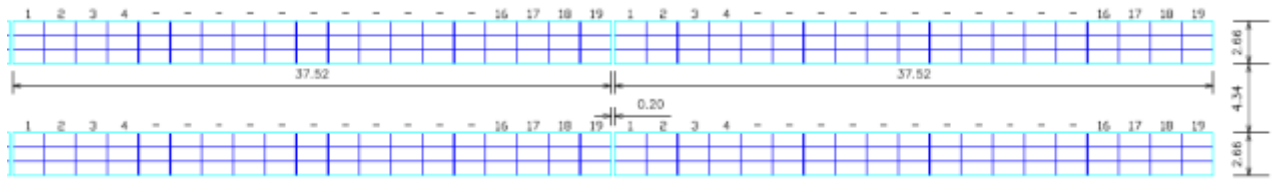
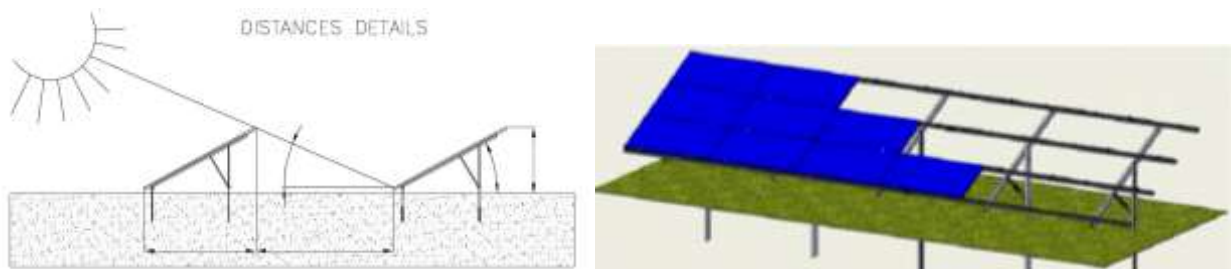

Figure 11 – Views of the PV structure



11.5 Foundations

The foundations depend on the structure itself, the wind requirements, the terrain characteristics, and the good durability strategy. For this reason there is not a general optimal solution and it always depends on the combination of the mentioned factors.

In later stages of the project, the choice of the type, shape and size will be handled as well as the structure type for supports and the loads transmitted to the foundation, taking into account the existing conditions the geological and geotechnical study of the location.

In any case, will be performed a geotechnical design of foundations with tolerable settlements ensuring a sufficient security against sinking collapse. Ensuring, at all times, an adequate strategy of durability for the service life of the solar plant.

11.5.1 Geotechnical analysis

The analysis of the geotechnical study for the Feasibility Study shows that the site is located in a flat area without vegetation coverage formed with rocky terrain of Andesite, Basalt and basaltic tuff from volcanic activity. The surface layer is formed with loose rocks, gravel and sand with capacity of open layer up to 100cm.

It is not detected water table in the studied length (deeper level studied 500cm).

The analysis of the geotechnical study concludes that:

1. There are three (3) stratification layers:
 - IEE-1: Alluvial sediments formed with loose rocks, gravel and sand. The open layer capacity is up to 100cm.
 - IEE-2: Fractured basaltic tuff and in some points disaggregated basaltic tuff. The open layer capacity is up to 210cm.
 - IEE-3: Andesites and gray basalt with high fracture degree up to 100cm and tending to be firmer as depth increases. The open layer capacity is up to 400cm.



2. The set of these three strata has a thickness of about 7.10m, being the thickness IEE-3, corresponding to fractured rock.
3. The soils broke through are not considered as suitable soils for driven steel profile. The possibility of driven steel profile with a pre-drilling shall be certificated through in site tests.
4. From a constructive point of view it could be required heavy machinery in some point of site but it is discarded the use of explosives due to high fracture degree of terrain.
5. The stability of the materials is good, being enough slopes of about 3H:2V but not discarding (using others studies) the use of 1H:1V slopes for embankments or clearings less than 2.0m.

Recommendations

The stratum IEE1 is considered as suitable for filling material in embankments, roads, etc. Likewise in absence of more detailed studies, this stratum is suitable as surface foundation level for buildings and power centers without need to reach deeper stratum.

The rocky character of site, though it shows high fracture degree up to 400cm, does not advise the driven steel profile of PV structures. It is not discarded the use of driven steel profile with a pre-drilling as suitable technique but shall be checked through in site tests to determinate its feasibility.

Finally, though the terrain is not suitable the driven steel profile of PV structures, it is feasibility for direct and surface foundation of PV structures, buildings and power centers without problems of water table and plasticity soils. All studied layers are suitable for this type of foundations.

For constructive project shall be:

- Studied and sized foundations direct type, analyzing the advantages and disadvantages of this type of foundations and shall be proposed isolated footings, combined footings, foundation beams and slabs. The final design will depend on structures for which it will be designed and the maximum loads that can be transmitted to the ground with safety range.
- Tested and checked the driven steel profile with pre-drilling to accept or discard this type of foundation for PV structure.

11.5.2 Photovoltaic structure

As a guide it may be mentioned that the foundations for the steel structure of photovoltaic modules generally are reinforced concrete footing or pile but shall be taken in account previous section "11.5.2. Geotechnical analysis" and annex "15.7 Dashtadem Geotechnical Report".

Alignment and allowable displacements (horizontal, vertical, angular deviation) in photovoltaic foundation shall fulfill the requirements of the provider.

Figure 12 – Krinner screw, reinforced concrete foundation and drive steel profile

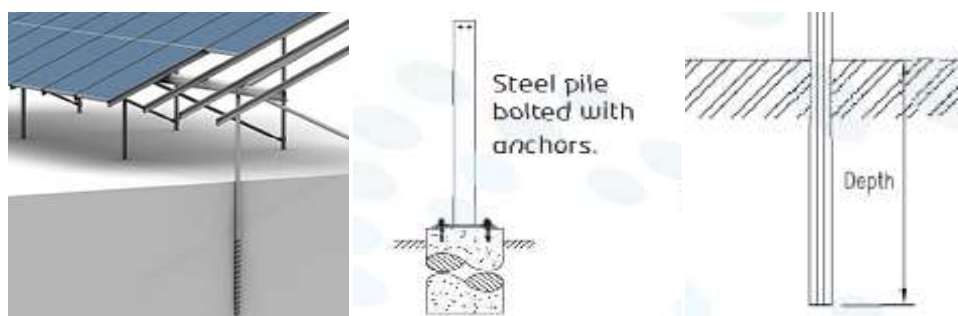



11.5.3 CC facilities

As a guide it may be mentioned for the CC, usually, the building slabs serves as foundation, preparing the contact area with a sand bed.

Figure 13 – Typical sketch

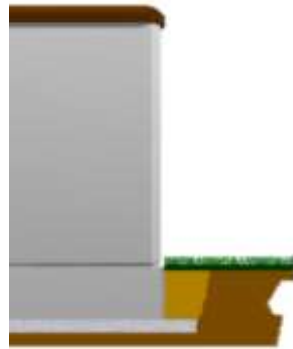

11.5.4 ITCs, Control building and Warehouse foundations

The foundations design of ITC's, Control building and Warehouse shall take into account the section "11.5.2. Geotechnical analysis", annex "15.7 Dashtadem Geotechnical Report" and further studies in addition to best economic and technical conditions.

Figure 14 – ITC foundation example

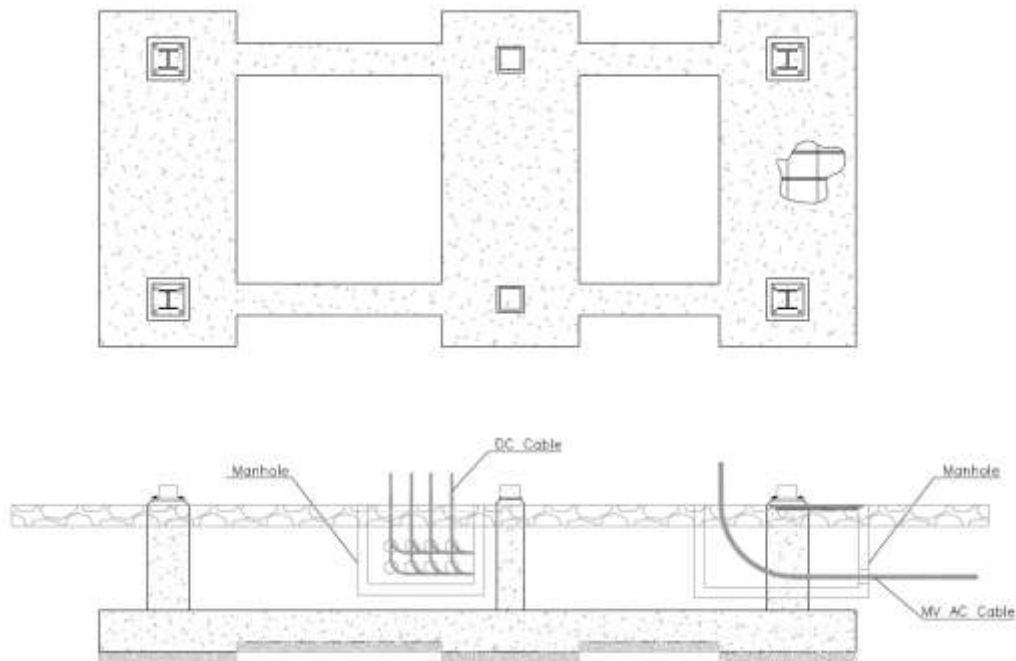
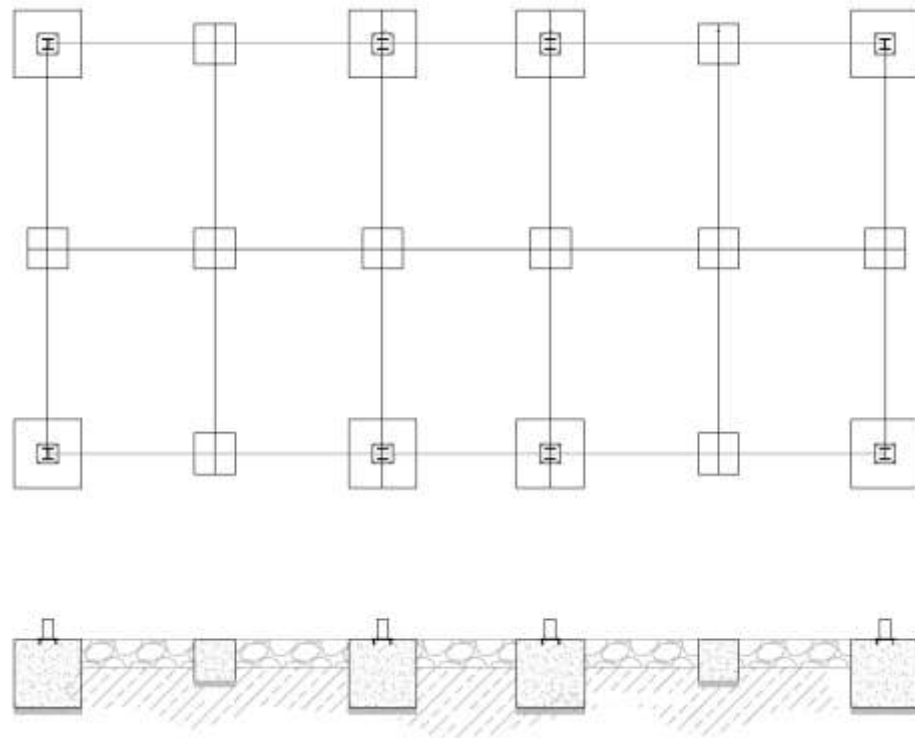



Figure 15 – Control Center and Warehouse foundation example



11.6 Drainage

A philosophy of drainage will be previously evaluated according to the site conditions that allow to decide the need of protection of the plant against floods, avoiding damage to people and facilities during the phases of construction, operation and maintenance.

11.7 Perimeter fence

Perimeter enclosure will be erected a perimeter fence 2m height with strands of barbed wire for security, with steel posts separated adequately and steel post reinforcement each 15 m and in each direction change. A galvanized steel wire mesh of simple twist at least, will be placed between the steel posts. Steel posts must be adequately installed on the ground for proper working of the fence. It will be taken into account the location of the accesses for the vehicles and pedestrians.

The perimeter fence will meet the environmental conditions.

11.8 Water system

The supply of fresh water can be performed via public network, water wells or water supply to the PV plant by trucks. Central or decentralized local network(s) on the PV plant can be developed and installed.

Water supply and distribution system have to be installed for all water needed including for module cleaning, potable water and fire fighting systems.

For the PV plant of Dashtadem it has be estimated around 218 m³ per year of water for the O&M labors of PV modules cleaning, and around 38 m³ per year of water for the O&M staff.



The total consumption of water per year is estimated in about 256 m³, which it involves around 26 tank trucks of 10000 liters of capacity, in case that public water network or water wells don't be available.

12 COST ESTIMATION

Cost estimation has been performed in order to show CAPEX & OPEX of the plant based on ARIES worldwide experience in other similar PV plants and on internal databases, as well as on the international market tendencies.

Due to project time schedule and estimation nature, costs may suffer variations when supplier negotiations are carried out in order to optimized plant costs and increase CAPEX and OPEX accuracy.

All equipment estimated costs are international market standard costs.

The following item cost is included in CAPEX (include both equipment and labor cost):

- EPC cost
 - Main equipment supply
- Modules
- Inverters, medium voltage transformers and MV switchgears (Power block)
- Mounting structure
- Combiner boxes
- MV connection center
 - Wires supply
- Electrical wiring
- Grounding
 - Evacuation line
 - Monitoring and security system
 - Installation works
- Civil works (including earth movement, urbanization and roads)
- Equipment and wiring installation
 - Other items:
- Spare parts
- Engineering & project management
- Contingencies (3% EPC cost)
- EPC profit (10% EPC cost)

Typical EPC profit for this kind of projects ranges within 7%-12%, with 10% as a common value.

- Developer cost
 - Permitting, licensing and legal
 - Owner's engineering
 - Project management and advisor's fees



- Insurances
- Pre-construction cost
- Land

Regarding OPEX estimation, the following lines show items breakdown considered:

- Salaries
- Surveillance
- Communications
- Consumables
 - Electrical consumption
 - Water consumption
- O&M management
- Insurances
- Contingency

Developer cost has been estimated based on similar projects. However this is a very project specific item that depends on the site legal, permitting and normative scenarios of the country. Therefore it is just estimated and should be fully analyzed in development phase.

For salaries, ARIES has considered local personnel cost provided by Client as follows:

- Plant manager salary 1500 USD/month
- Maintenance workers salary 700 USD/month
- Non qualified personnel salary 250 USD/month

The following table shows CAPEX and OPEX estimation breakdown:



Table 12 - CAPEX estimation breakdown

ITEM	COST (US DOLLARS)	\$/Wp
Main equipment supply	6.913.933	0,55
Modules	3.742.848	0,30
Power blocks (inverters)	1.152.941	0,09
Structure	1.702.123	0,14
Combiner boxes	132.883	0,01
MV connection center	183.138	0,01
Wiring supply	467.054	0,04
Electrical DC wiring	341.816	0,03
Electrical AC wiring	64.288	0,01
Grounding	60.950	0,00
Evacuation facilities	124.024	0,01
Substation	0	0,00
Evacuation line	124.024	0,01
Monitoring & Security system	548.218	0,04
Installation works	2.786.256	0,22
Civil works	1.857.312	0,15
Earth movement	891.827	0,07
Trenches and manholes	562.461	0,05
Urbanization (roads, buildings, fence...)	403.023	0,03
Equipment and wiring installation	928.944	0,07
Spare parts	120.798	0,01
Engineering & Project Management	270.987	0,02
Contingencies (3% EPC cost)	336.938	0,03
EPC profit (10% EPC cost)	1.156.821	0,09
TOTAL EPC COST	12.725.029	1,02
Development costs	378.798	0,03
Land	53.830	0,00
TOTAL DEVELOPER COST	432.629	0,03
TOTAL CAPEX	13.157.657	1,05



Table 13 - OPEX estimation breakdown

ITEM	COST (US DOLLARS)	\$/Wp
Salaries	57.236	0,005
Surveillance	8.915	0,001
Communications	11.143	0,001
Consumables (electrical, water)	4.624	0,000
O&M Management	77.427	0,006
Contingencies	1.593	0,000
Insurances	38.175	0,003
TOTAL OPEX	199.113	0,016

13 FINANCIAL ASSESSMENT

13.1 Introduction

The financial analysis is presented in the current report, of which an overview is provided hereinafter.

Key assumptions for the financial analysis are presented in chapter 13.2. The key assumptions address mainly capital investments and financing, tariffs and ROE targets.

The energy volume projections are addressed in chapter 13.3. The project investments and concerned cost estimates, as well as investment financing aspects are dealt with under chapter 13.4. Operational costs of the project (OPEX) are presented in chapter 13.5.

Project tariffs, revenue, I/S and cash-flow projections are highlighted in chapter 13.6. The financial analysis with the provision of concerned ratios and indicators, as well as a sensitivity analysis are presented in chapter 13.7.

The project conclusions and recommendations are summarised in chapter 13.8.

13.2 Key assumptions

The financial analysis and forecasts for the purpose of this study are based on the key assumptions summarised in the following table:

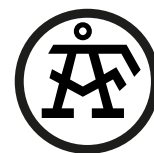

Table 14 - Key assumptions for financial analysis and forecasts

Nº	Descriptions	Assumptions	Comments
1	Project time horizon	20 years of operations after commissioning of project investments;	
2	CAPEX	CAPEX cost estimates are developed for the envisaged construction year 2017;	
3	Assets useful life (UL)	An average asset UL of 20 years is considered;	
4.	Depreciation	20 years depreciation are considered according to the Armenian regulation	
4	OPEX: Cost price escalation factor	A cost price escalation factor has been considered for determining OPEX throughout the projection period, based on cost estimates for the year 2017;	Factor determined based on projected Armenian inflation rate;
5	Tariff	The financial model considers a tariff scenario, which allows the achievement of the targeted IRR of equity indicated hereinafter; throughout the projection period	Tariff fixed in US\$ for the whole period. No tariff escalation has been made
7	Equity IRR	A target factor of 13 % has been established for the IRR on Equity	

13.3 Energy volume data projections

For the purpose of the financial analysis the envisaged energy generation projections for the considered generation plant are determined based on the technical indicators presented in the corresponding chapter of this report.

In line with the project projections - for the base performance -, an annual degradation factor of 0.5 % was applied on the number of working hours per year.

A power generation overview for selected years is presented in the following table.

Table 15 - Power generation overview

		2018	2019	2020	2021	2022	2027	2032	2037
Peak capacity	MWp	12,47	12,47	12,47	12,47	12,47	12,47	12,47	12,47
Nominal capacity	MW	10,47	10,47	10,47	10,47	10,47	10,47	10,47	10,47
Hours in the period	hours	2.063	2.053	2.042	2.032	2.022	1.972	1.923	1.876
Energy output	MWh	21.380	21.273	21.166	21.060	20.955	20.437	19.931	19.437
CPI	Index	105%	108%	110%	113%	116%	131%	148%	168%
Tariff, incl. VAT	US\$/kWh	0,116	0,116	0,116	0,116	0,116	0,116	0,116	0,116
Revenue	US\$	2.475.100	2.462.725	2.450.411	2.438.159	2.425.968	2.365.922	2.307.363	2.250.253
	VAT US\$	(412.517)	(410.454)	(408.402)	(406.360)	(404.328)	(394.320)	(384.560)	(375.042)
Net Revenue	US\$	2.062.583	2.052.271	2.042.009	2.031.799	2.021.640	1.971.602	1.922.802	1.875.211

As indicated in above table, the plant generation will be 21.38 GWh in the first production year and 19.43 GWh by the end of the projection period.



13.4 Projections of capital investment costs and financing

13.4.1 Project investments and cost estimates (CAPEX)

The financial analysis is presenting data for the project scenario as defined in the corresponding chapter of the current report, whereby proposed investment costs have been taken into consideration.

The project investment cost estimates (cost base: year 2017) are determined in line with the methodology presented in the relevant chapter of this report. The principal CAPEX components concern equipment, civil works and engineering and other costs. Investment related VAT charges will be recovered during the projection period.

An overall capital investment cost summary is shown in the following table.

Table 16 - CAPEX

	TOTAL CAPEX (US\$)
Engineering and works management	339.257
Equipment	7.787.859
Imported	7.787.859
Local	-
Civil works, installations and BOP	4.181.681
Civil works	2.043.043
Installations	1.021.839
BOP	1.116.799
Grid Connection	136.426
Contingencies	422.014
Import duties	-
EPC cost	12.867.237
Development costs	391.147
Land	53.830
VAT	-
Total CAPEX	13.312.214

TOTAL INVESTMENT COST	US\$	13.714.733
CAPEX	US\$	13.312.214
Working capital	US\$	16.792
Commitment/front-end fees and interest during construction	US\$	385.727
Interest	US\$	334.297
Front-end fee	US\$	-
Commitment fee	US\$	51.430

As highlighted in the above table, the total project capital investment volume is estimated at \$13.71 M.

13.4.2 Financing of project investments

The project CAPEX financing is envisaged to be performed by commercial banks and equity.



For the base case, (scenario 3) the overall financing scenario of the current project is summarised in the following table.

Table 17 - Overall project financing scenario

Sources of funding	
Equity	\$ 3.428.683
Debt	\$ 10.286.050
Total	\$ 13.714.733

Sources of debt financing	
IBRD loan	-
SREP credit	-
IBRD guarantee covered commercial	-
Uncovered commercial	10.286.050
Total debt financing	10.286.050

The relevant Debt conditions are summarised in the following table.

Table 18 - Summary of loan conditions

Terms of debt financing		IBRD guarantee covered commercial	Uncovered commercial
% of Total debt financing	%	0%	100%
Amount of financing	US\$	-	10.286.050
Maturity	Yrs	12	12
Grace period	Yrs	1	1
Fixed rate	%	4,00%	6,50%
Margin	%	0,00%	0,00%
Front-end fee	%	0,00%	0,00%
Commitment fee	%	0,50%	0,50%

13.5 Projections of Operational Costs

13.5.1 OPEX

In line with the OPEX cost estimates presented in the corresponding chapter of the current report, the project scenario envisages the following main cost components: An OPEX cost overview for selected years is presented in the following table.



Table 19 - OPEX cost - (US\$)

		2018	2019	2020	2021	2022	2027	2032	2037
Operating and maintenance costs	US\$/Wp	(214.648)	(220.014)	(225.514)	(231.152)	(236.931)	(268.066)	(303.292)	(343.147)
Salaries	US\$/Wp	(60.104)	(61.607)	(63.147)	(64.726)	(66.344)	(75.062)	(84.926)	(96.086)
International qualified	US\$/Wp	(18.902)	(19.374)	(19.859)	(20.355)	(20.864)	(23.606)	(26.708)	(30.218)
Local qualified	US\$/Wp	(17.642)	(18.083)	(18.535)	(18.998)	(19.473)	(22.032)	(24.927)	(28.203)
Local non-qualified	US\$/Wp	(23.561)	(24.150)	(24.753)	(25.372)	(26.006)	(29.424)	(33.290)	(37.665)
Spare parts and supplies	US\$/Wp	(25.918)	(26.566)	(27.230)	(27.911)	(28.609)	(32.368)	(36.622)	(41.434)
Insurance and others	US\$/Wp	(128.625)	(131.841)	(135.137)	(138.515)	(141.978)	(160.635)	(181.744)	(205.627)

The OPEX cost estimates consider an impact of inflation on local costs throughout the projection period.

13.6 Tariffs, revenue projections, I/S and Cash-Flow

13.6.1 Tariff calculation scenarios

The Financial Model incorporates a tariff calculation modality in order to achieve a targeted 13% Shareholders' equity throughout the projection period.

The tariff base scenario is a flat tariff, which does not foresee a tariff growth rate throughout the entire period.

A flat tariff of US\$ cents 9.63 (11.56 including VAT) is estimated for the whole 20 years period.

13.6.2 Revenue projections

In line with the energy volume data projections presented in chapter 13.3 and the tariff calculation scenario described in chapter 13.6.1, the revenue figures have been projected.

A revenue overview for selected years is presented in the following table.

Table 20 - Revenue overview

		2018	2019	2020	2021	2022	2027	2032	2037
Peak capacity	MWp	12,47	12,47	12,47	12,47	12,47	12,47	12,47	12,47
Nominal capacity	MW	10,47	10,47	10,47	10,47	10,47	10,47	10,47	10,47
Hours in the period	hours	2.063	2.053	2.042	2.032	2.022	1.972	1.923	1.876
Energy output	MWh	21.380	21.273	21.166	21.060	20.955	20.437	19.931	19.437
Tariff, incl. VAT	US\$/kWh	0,116	0,116	0,116	0,116	0,116	0,116	0,116	0,116
Revenue	US\$	2.475.100	2.462.725	2.450.411	2.438.159	2.425.968	2.365.922	2.307.363	2.250.253
	VAT	(412.517)	(410.454)	(408.402)	(406.360)	(404.328)	(394.320)	(384.560)	(375.042)
Net Revenue	US\$	2.062.583	2.052.271	2.042.009	2.031.799	2.021.640	1.971.602	1.922.802	1.875.211

As presented in above table, the annual net revenues will vary only very slightly throughout the projection period as a consequence of the applied degradation factor.

13.6.3 Projections of I/S

The I/S projections of the FM present the following main elements:

- Income,
- OPEX,
- Financial expenditures, and
- Income taxes



Details of highlighted main elements are presented in previous chapters of this report to which reference is being made.

An I/S projections overview for selected years is presented in the following table.

Table 21 - I/S projections overview

		2018	2019	2020	2021	2022	2027	2032	2037
Net Revenue	US\$	2.062.583	2.052.271	2.042.009	2.031.799	2.021.640	1.971.602	1.922.802	1.875.211
Operating and maintenance costs	US\$/Wp	(214.648)	(220.014)	(225.514)	(231.152)	(236.931)	(268.066)	(303.292)	(343.147)
EBITDA	US\$	1.847.936	1.832.257	1.816.495	1.800.647	1.784.709	1.703.536	1.619.511	1.532.064
Depreciation	US\$	(682.206)	(682.206)	(682.206)	(682.206)	(682.206)	(682.206)	(682.206)	(682.206)
EBIT	US\$	1.165.730	1.150.051	1.134.289	1.118.442	1.102.504	1.021.331	937.305	849.859
Interest expense	US\$	(638.203)	(577.421)	(516.640)	(455.859)	(395.078)	(91.172)	0	0
EBT	US\$	527.528	572.630	617.649	662.582	707.426	930.159	937.305	849.859
Corporate tax	US\$	(105.506)	(114.526)	(123.530)	(132.516)	(141.485)	(186.032)	(187.461)	(169.972)
Net profit	US\$	422.022	458.104	494.119	530.066	565.941	744.127	749.844	679.887

The net income is gradually increasing during the first 20 years of the projection period. Subsequently, and as a consequence of debt service reduction and the complete amortisation of the CAPEX.

The Corporate Income Tax is determined at a rate of 20% of taxable income in line with national regulations.

13.6.4 Cash flow projections

The projections of the project cash flow consider the following main components in line with the I/S model, but adjusted by elements in order to comply with cash flow criteria.

An overview of cash flow projections for selected years is presented in the following table.

Table 22 - Overview of cash flow projections

	2017	2018	2019	2020	2021	2022	2027	2032	2037
OPERATING CASH FLOWS									
Net profit	-	422.022	458.104	494.119	530.066	565.941	744.127	749.844	679.887
[+] Depreciation	-	682.206	682.206	682.206	682.206	682.206	682.206	682.206	682.206
[+] Interest expense	-	638.203	577.421	516.640	455.859	395.078	91.172	(0)	(0)
[+/-] Decrease/Increase in net working capital	-	(287.507)	1.967	1.970	1.974	1.978	2.003	2.037	2.082
[+/-] Decrease/increase in tax assets	-	-	-	-	-	-	-	-	-
After-tax operating cash flows	-	1.454.923	1.719.698	1.694.935	1.670.104	1.645.202	1.519.508	1.434.087	1.364.174
INVESTMENT CASH FLOWS									
Capital expenditure	(13.312.214)								
Financing cost	(385.727)								
Total investment cash flows	(13.697.941)								
FINANCING CASH FLOWS									
Equity funding	3.428.683								
Debt funding	10.286.050								
Interest payment	-	(638.203)	(577.421)	(516.640)	(455.859)	(395.078)	(91.172)	0	0
Principal payment	-	(935.095)	(935.095)	(935.095)	(935.095)	(935.095)	(935.095)	-	-
Total financing cash flows	13.714.733	(1.573.298)	(1.512.517)	(1.451.736)	(1.390.954)	(1.330.173)	(1.026.267)	0	0
Net cash flows	16.792	(118.375)	207.181	243.200	279.150	315.029	493.241	1.434.087	1.364.174

An important element of the cash flow analysis is the project's capacity to generate sufficient financial resources in order to attend the debt service requirements. The concerned project indicator, DSCR is presented hereinafter:



Table 23 - DSCR projections

	2017	2018	2019	2020	2021	2022	2027	2032	2037
DSCR	N/A	0,92	1,14	1,17	1,20	1,24	1,48	N/A	N/A
Min DSCR	0,92								
Average DSCR	1,28								

Consequently, the achieved average DSCR guarantees the project financiers an adequate overall debt service ratio, although a low DSCR would occur the first year which would be easy to assess during the final structuring of the Project.

13.7 Financial Scenarios

13.7.1 General aspects of financial analysis

Different CAPEX financial scenarios were considered according to the conversations with the client and with the WB. The scenarios and the resulting tariff are shown in the following table:

Table 24 - I/S Financial scenarios

Costs in MUS\$	Scenario 1: Public project	Scenario 2: Private project with World Bank guarantee (for termination payment)	Scenario 3: Fully private project
EPC, development, land acquisition, and financing costs (in MUS\$)	13.49	13.65	13.72
Equity (in MUS\$)	3.37	3.41	3.43
Concessional sovereign-guaranteed loan	10.12	0	0
Uncovered commercial debt (in MUS\$)	0	3.71	10.29
Covered commercial debt (in MUS\$)	0	6.53	0
Estimated tariff in USc/kWh (VAT exclusive)	6.36	9.27	9.63

The base case (Scenario 3) shows fully commercial financing, Scenario 2 shows finance using 64% of Commercial Debt covered with a World Bank Guarantee and 36% of uncovered commercial loan, and Scenario 1 shows fully multilateral-concessional financing.

13.7.2 Sensitivity Analysis

A number of factors can influence the results situation, cash flows and the conclusions of the base case scenario. In order to test the soundness of the base case analysis several adjustments have been made to key variables. The testing was performed on several selected individual factors. The following sensitivity tests on individual factors were performed:

- Increase and decrease of projected investment costs,
- Variation of Debt/equity Ratio, and



- Variation of Equity Remuneration.

13.7.2.1 Increase and decrease of projected investment costs

We have assessed the impact of increase or decrease of project CAPEX. The results are shown in the following table:

Table 25 - Impact of CAPEX variation

CAPEX	Tariff US\$ cents/kWh
CAPEX +20 Table 26 - %	11.18
CAPEX +10%	10.41
Base Case	9.63
CAPEX -10%	8.87
CAPEX -20%	8.09

As PV cost is historically lowering is expected a reduction of capex by 2017-2018. However, some other socio-economic factors can affect and make CAPEX grow in the future. The impact of both cases are shown in the table.

13.7.2.2 Variation of Debt/equity Ratio

We have assessed the impact of Different level of leverages by investors. The results are shown in the following table:

Table 27 - Impact of D/E ratio variation

Debt Equity ratio	Debt	Equity	Tariff US\$ cents/kWh
Base Case	75%	25%	9.63
Scenario B	80%	20%	9.46
Scenario C	65%	35%	9.96

The result shows that decreasing leverage rates by 10% produces an increase in tariff in US\$ cents of 0.33.

13.7.2.3 Variation of Equity Remuneration

We have assessed the impact of Different level of remuneration to equity investors . The results are shown in the following table:

Table 28- Impact of equity remuneration

Scenario	Equity IRR	Tariff US\$ cents/kWh
Base Case	15%	9.63
Scenario I	10%	8.89
Scenario II	20%	12.46



13.8 Conclusions and recommendations

The project is feasible from the financial point of view. It is important to highlight that the estimated tariff is “flat type” so no actualization is considered in the value for the whole life of the plant, which implies that the first years is higher than a tariff linked to any cost performance index but, on the opposite side, the last years is lower.

In any case, it is suggested to prepare a sound legal framework to help the developers to reduce the profit required which, as shown in the sensitivity analysis, may have a strong impact.

On top of this, it is paramount to design a proper bidding process to achieve a high level of competition which could optimize the estimated investment costs and reduce the tariff.



14 DRAWINGS

Table 29 - Drawings

CODE	TITLE	REV.
PEF2827-041-Dashtadem 1-LOC	General Situation	0
PEF2827-018-Dashtadem 1 Layout	General Layout	4
PEF2827-037-Dashtadem 1-BLOCK LAY	Block layout	2
PEF2827-039-Dashtadem 1-ROADS	Access and Internal Roads	3
PEF2827-040-Dashtadem 1-MV LINE LAY	Medium Voltage Lines Layout	2
PEF2827-042-Dashtadem 1-DC SLD	DC Single Line Diagram	2
PEF2827-038-Dashtadem 1-MV SLD	Medium Voltage Single Line Diagram	1
PEF2827-043-Dashtadem 1-ITC BUILD	Inverter Transformer Center Building	0
PEF2827-044-Dashtadem 1-WARE&CB BUILD	Warehouse & Control Building	1
PEF2827-046-Dashtadem 1-CC BUILD	Connection Center Building	0
PEF2827-047-Dashtadem 1-GRND-R00	General Grounding	2
PEF2827-045-Dashtadem 1-MV CONNECT SLD	Interconnection Single Line Diagram	2
PEF2827-056-Dashtadem 1-OHL ROUTE	Overhead Transmission Line	2
PEF2827-052-Dashtadem 1-Topographic map	Topographic map	1



15 ANNEXES

Table 30 - Annexes

CODE	TITLE	REV.
15.1 EN-JKM320P-72(4BB)	Module data sheet	0
15.2 INGECON SUN 1165TL B420 Outdoor	Inverter data sheet	0
15.3 R02-LOE-130409	Meteorological station datasheet	0
15.4 Dashtadem EYA	Energy Yield Assessment	0
15.5 PEF2827-049-Dashtadem 1-BOM	Bill of materials	1
15.6 PEF2827-124-Risks Matrix	Risk Matrix	0
15.7 Dashtadem 1 Geotechnical Report - Dashtadem.Sectional drawing - plan -01.dwg-eng - razrez-02,03,04,05arm.dwg-eng	Geotechnical Investigation Technical Report	0



For further information or any clarification to this document, please contact:



AF ARIES ENERGÍA, S.L.
Oficinas centrales
Paseo de la Castellana, 130
28046 Madrid, Spain
Tel.: +34 91 579 52 42
www.afconsult.com

Dr. Ralf Wiesenberg
Managing Director
ralf.wiesenberg@afconsult.com